

THE LEADER IN AFFORDABLE MACHINE SOLUTIONS



COMPACT GT27

Fagor 8025TG

Operation & Programming Manual

Compact Manufacturing Systems
638 North Poinsettia, Santa Ana, CA 92701
Internet: www.upgrade-tech.com • E-Mail: sales@upgrade-tech.com
Toll Free 888-664-TURN or 714-664-8800 • Fax : 714-664-0860

A DIVISION OF UPGRADE TECHNOLOGIES

Table of Contents

GT27 Operation Manual		Page #
	Table of contents	2-4
	Customer warranty	5
	Machine outline	6
	Standard equipment	7
	Optional equipment	7
	Machine specification	8
Section 1	Safety	9
	Safety instructions	10
	Levels of safety	11
Section 2	Machine installation	12
	Pre delivery Inspection	13
	Selecting a location	14
	Connecting the utilities	15
	Phase testing the power	16
	RS232 Connection to a computer	17
	Machine connection locations and lubrication chart	18
Section 3	Drawbar Actuators	19
	Drawbar activation and changing collets	20
	Drawbar operating instructions (holding force adjustment)	21
Section 4	Fagor 8025 Screen layout	22
	Screen and keyboard layout	23-26
	Feedrate override knob	27
	Secondary control panel	28
Section 5	8025TG CNC Programming	29
	Cartesian Coordinates	30
	Radius and diameter programming	30
	Machine coordinate system	31
	Table tooling layout	32
	Miscellaneous M codes	33-34
	G code modality	35
	G code explanations (G00-G01)	36
	G code explanations (G02)	37
	G code explanations (G03-G39)	38
	G code explanations (G40-G92)	39
	Feedrate commands (G94-G95)	40
	Spindle Commands (G96-G97)	41
	Spindle Orientation (M19 S)	42
	Other addresses I & K	43
	Block numbers	43
	Other addresses (P-Z)	43
	Using Tool offsets	44
	G25 Unconditional Jump	45-46
	Automatic radius and chamfering G36-G39	47
	Toolnose radius compensation	48
	Tool tip registers	48
	Compensation directions	49
	Basic Format for a program Start up sequence	50
	Basic Format for a program Ending sequences	51
	Sample 2 axis program without canned cycles	52
	Explanation of sample program	53
	Sample 2 axis program with canned cycles	54
	Sample barfeed program	55

Table of Contents

Section 6	8025TG canned cycle programming	56
	Canned cycle variables P0-P19	57
	G68 Roughing in Z axis (Format)	58
	G68 Roughing in Z axis (Sample program)	59
	G83 Peck drilling cycle (Format)	60
	G83 Peck drilling cycle (Sample program)	61
	G86 Threading Cycle (Format)	62
	G86 Threading Cycle (Sample program)	63
Section 7	General threading information	64
	Maximum threading feedrates related to spindle speed	65
	Thread depths for UN and UNJ threads	66
	UN and UNJ external root radii values	67
	Thread repeating	68
	Establishing a start point for threading	69
	Acceleration and deceleration when threading	69
	Plunge and compound infeed	69
	Pipe threads	70
	Left & Right hand threads	71
Section 8	Fagor 8025TG Operation	72
	Power up procedure	73
	Changing the program to run	73
	Setting a tool offset	74
	Tool offsetting directions	75
	Setting a value for manual operation	75
	Using the editor (Menu prompts)	76
	Starting a new program	77
	Accessing an existing program	77
	Renaming an existing program	77
	Copying an existing program	78
	Deleting an existing program	78
	Sending a program to a PC	79-81
	Receiving a program from a PC	82
Section 9	Trigonometry for programming	83
	Basic Triangle solving	84-93
	Chordal length problems	94
Section 10	Advanced Features for Programming	95
	Alternatives for Position Input	96
	Angles and X coordinates	96
	Angles Radii and X coordinates	96
	Angles and Z coordinates	97
	Angles Radii and Z coordinates	97
	Parametric variables	98
Section 11	Manual tool nose radius compensation	99
	Manual calculation	100
	Theoretical sharp point	100
	Calculation and application	100
	External Radius Calculation	101
	Internal Radius Calculation	102
	Taper Calculation	103
	Toolnose radius compensation chart	104
	Calculating rear compensation when plunging	105

Table of Contents

Appendix 1	Parameters for 8025 TG controller	106
	Standard parameter settings 0-99	107
	X Axis	107
	Z Axis	108
	Binary parameters	109
	Reversing X axis travel directions	110
	Reversing X axis graphics directions	111
Appendix 2	Amplifier Information	112
	Servo dynamics specification	113
	Servo Fault indications	114
	Troubleshooting the LED's	115
Appendix 3	Spindle Amplifier Information	116
	Non indexing spindle EMS drive system	117
	Vector drive system	117
Appendix 4	Machine Parts List	118
	Part number list	119-121
	Exploded view	122
Appendix 5	Trouble shooting guide	123
	Troubleshooting list	124-127

Written by R.W.Turney

Copyright © 1997 Compact Manufacturing Systems Inc. World rights reserved.

No part of this publication may be stored in a retrieval system, Transmitted, or reproduced in any way, including but not limited to photocopy, photograph, magnetic or other record, without the prior written permission of the copyright holder.

Customer Warranty

CMS. acts only as an agent for non-proprietary components which prove defective in material or workmanship during the following warranty period. The warranty period is one (1) year from the date of shipment. Field Service Labor charges will be charged at the published rates and any travel charges will be billed at cost, such as travel and subsistence as necessary.

General Warranty conditions are as follows:

1. All warranty coverage is F.O.B. CMS. Santa Ana, CA
2. The warranty period for material is one (1) year from the date of shipment, exclusive of any materials considered as consumables, such as lubricants and filters. The warranty coverage period for labor in support of a **New** system is Ninety (90) days from the date of shipment, exclusive of travel and subsistence expenses.
3. The choice of repair or replacement of warranty items will be the exclusive choice of CMS.
4. Items replaced under warranty will be covered for the unexpired portion of the original warranty. Materials and labor provided to customers on systems under warranty for the purpose of correcting failures due to improper use, maintenance or configuration changes of the system are specifically excluded from any warranty coverage for either labor, material or expenses incurred in providing the service.
5. This warranty does not cover improper usage, installation, maintenance or damages that occur during shipping.
6. CMS. shall be held blameless for any "Loss of Use" considerations due to warranted or unwarranted interruptions in use of this operating system.

This expressed warranty is valid only for systems in normal use, service, and operating conditions as defined in specifications and the operating and maintenance sections of this manual, specific for each individual system. The purchaser must notify **CMS.** of any "defect" and request an RMA number for the return of any defective part. To qualify for warranty coverage, the defective part must not have failed from any misuse or abuse due to non-normal operating conditions.

The use of water based coolants impose extreme demands on mechanical systems and lubricants. Since CMS. cannot anticipate the actual conditions of use of any of these systems, specific maintenance and lubrication intervals are not specified. The end user, through their experience must determine appropriate maintenance requirements for their conditions of usage.

Contacting Compact Manufacturing Systems

Please contact us at (888)664-TURN

Service : John Clark
Parts : Nan Crippen
Applications : Roger Turney

Machine Outline

The GT27 (Gang Tool, 27mm through spindle capacity) is a complete, state of the art, high speed, high accuracy turning system that incorporates the production rates of an automatic screw machine with the versatility of a lathe, while utilizing the flexibility of a modern industrial hardened, CNC controller.

This machine tool system, like all machine tool systems, is made up of a marriage of a mechanical and an electronic system. In the GT27, the components in both systems were chosen for their quality, durability and accuracy, not their cost.

Spindle Configurations

The GT27, in its Standard Configuration, provides all the necessary options and accessories required for a high rate production turning system. There are, however, three configuration options that increase the specialized application efficiency of the system without compromising the standard turning efficiency. The three optional configurations are: Indexing Spindle, which provides a position and hold capability for the spindle with 1° accuracy and repeatability, Full "C" Axis capability with the Spindle being a fully interpolated third axis, and 6000 rpm spindle speed option.

Guideway Configuration

The mechanical system is based on NSK 25mm, super precision, four circuit linear bearings, NSK Angle Load Thrust Bearing assemblies supporting ultra accurate five pitch, four circuit ballscrews. Direct coupled to high torque, rare earth servo motors. The entire assembly is covered and protected from direct contact with either chips or coolant by a combination of ridged and moving covers and lubricated by an automatic, pressurized, continuous lubrication system.

Servo and motor Configuration

The electrical /electronics systems begin with the high speed, high torque, rare earth servo motors driven by high powered, pulse width modulated servo power amplifiers which provide axis rapid speeds of 600 inches per minute and peak thrust in excess of 800 pounds. The servo motors have the tachometer and 1000 line rotary encoders incorporated in the servo motor assembly which completes the axis positioning system feedback to the CNC Turning controller. This combination provides .0001 inch resolution for positioning accuracy of .0001 inch and repeatability of .00005 inch.

Spindle motor Configuration

The spindle drive inverter is a variable speed, constant 5 hp, 3 phase ac powered unit in the standard Lathe, and an AC flux vector technology drive inverter in the Indexing Spindle and "C" Axis configurations. All lathe configurations have 4500 rpm spindle limits except when the 6000 rpm spindle option is selected.

All GT27 lathes have a CNC controller, automatic collet closers, high volume coolant pumps, electronic handwheels, full chip enclosures, internal waterproof work light and extra M Function outputs as standard equipment.

All this adds up to one of the most complete and best integrated turning systems available and probably the best value in the machine tool market today!

Standard Features

- Fagor 8025 TG, Fagor 8050 TG
- A2-4 5C collet nose
- Air powered drawbar actuator
- Work light
- Automatic pressurized lubrication system
- Stainless steel telescoping way covers
- Coolant system (15 gallon capacity)
- Full chip and coolant enclosures
- Leveling bolts and plates
- Leveling Pads
- Environmental safety tray
- Operation and maintenance manuals
- Parts list and electronic drawings
- One year machine warranty
- One year control warranty

Optional Features

- Positioning spindle (1^o increment)
- Full C axis spindle (Allows contouring of shapes with live tools, requires 8050TG)
- 6000 rpm spindle
- Parts catcher
- Parts conveyor
- Sub spindle
- 8 station turret
- Live tools (NSK air or electric)

Machine specifications

CAPACITY	GT27	
Maximum Bar Capacity	1.0625"	(27.0mm)
Maximum Turning Length	8.0"	(203.2mm)
Maximum Turning Diameter	10.0"	(254.0mm)
Maximum Swing over ways	13.0"	(330.2mm)
HEADSTOCK		
Spindle / Nose Internal Taper	A2-4	
Hole Through Spindle	1.25"	(31.75mm)
Max. Chuck Diameter	5"	(127.0mm)
Spindle Speed	4500 rpm	
Spindle Motor	5 hp high torque	(11kw)
X AXIS		
Travel	11.75"	(298.4mm)
Rapid Traverse Rate	600"/ min.	(15240.0mm)
Max. programmable feedrate	200"/ min.	(6350.0mm)
AC Servo Motor	600"/ lbs.	(1320n/m)
Z-AXIS		
Travel	7.5"	(190.5mm)
Rapid Traverse Rate	600"/ min.	(15240.0mm)
Max. programmable feedrate	200"/ min.	(6350.0mm)
AC Servo Motor	900"/ lbs.	(1980n/m)
MACHINE DIMENSIONS		
Height	63"	(1600mm)
Width	36"	(915mm)
Depth	48"	(1220mm)
Weight	2200 lbs.	(4840kg)

(fig 1.1)

Section 1

Safety

Safety Instructions

- Please do not operate your machine until you have studied the machine and have read this manual.
- Always close and lock the electrical cabinets prior to operating the machine, and only allow qualified electrical technicians to perform service on these electrical connections.
- The high voltage power supply to your machine can **KILL** or severely injure you. Always turn off the main breaker before opening cabinets.
- **NEVER** attempt to service or repair electrical circuit's unless you are qualified to work safely on electronic circuit's, or are an Upgrade Technologies authorized Technician.
- Revolving parts and devices inside the working envelope of the machine can cause severe injury if not used properly, use caution when operating this machine.
- Do not remove any covers or panels from the machine, rotating pulleys and slide can cause severe injury.
- Compressed air is connected to this machine for machine use only. Compressed air can KILL or seriously injure you. NEVER work on compressed air systems without disconnecting the compressed air source. Prior to work always bleed down any residual air in the systems. Only qualified technicians familiar with the compressed air systems should perform work on these compressed air systems.
- **MODIFICATIONS, ALTERATIONS AND CHANGES TO THE MACHINE REQUIRE THE WRITTEN AUTHORIZATION OF Upgrade Technologies Inc.,**
Address any questions to Upgrade Technologies. Attention to the Service Department Manager.
- **UNAUTHORIZED CHANGES MAY LEAD TO HAZARDOUS CONDITIONS.**

DANGER

DANGER - Immediate hazards which **WILL** result in severe personal injury or death.

WARNING

WARNING - Hazards of unsafe practices which **COULD** result in severe personal injury or death.

CAUTION

CAUTION - Hazards of unsafe practices which **COULD** result in minor personal injury or product or property damage.

Any machine that is operated in a careless or improper manner can cause serious injury or death and damage to the machine itself. The warnings in this manual follow accepted industry safety guidelines.

Upgrade Technologies cannot have control of an individual company applications or production methods, and is not responsible for injuries or equipment damage when the machine is not used according to safe industry practices.

The safe use and disposal of toxic or hazardous chemicals or materials processed on a machine are the responsibility of the user.

It is the sole responsibility of the end user of the machine to comply with all local, state, and federal safety laws and regulations applicable to their machine and its use.

Section 2

Machine Installation

Pre-Delivery Inspection

Machine Packaging

When your GT27 arrives, it will either be in a large plywood box or on a heavy wood skid and wrapped with plastic stretch wrap. The shipping preparations will depend on the shipping method and distances involved. Actually, the packaging is the same except for the addition of the plywood sides and top when the machine is being transported on an open trailer or if the transportation will take over one day.

If your machine arrives with the plywood protection, remove the drywall screws holding the plywood together, starting with removal of the top, then the sides .

The machine is now visible through the stretch wrap and a careful inspection as the unpacking continues is essential.

If shipping damage is discovered:

1. Stop unpacking and contact Upgrade Technologies to determine the appropriate course of action to follow, as it will vary, depending on the type and extent of damage.
2. Document the damage with a clear, complete description of the conditions and the names of people present, and take photographs if possible.
3. If there are multiple incidence of damage, document each incidence individually, as if it were the only one.
4. Remember, shipping damage **is not** covered under the warranty, and is generally an issue that will have to be resolved between you and the carrier, with Upgrade Technologies support and assistance.

Normal Unpacking of the machine:

- Carefully cut and remove the stretch wrap and inspect the machine again for any signs of damage.
- Referring to your sales order and the packing list, take complete inventory of the items shipped with the machine to be sure the shipment is complete, and includes all hardware, options and documentation listed on the sales order and packing list. Report any shortages to Upgrade Technologies as soon as they are identified.
- Note that the machine is secured to the skid by four metal hold down brackets and lag screws. (Save the hold down brackets to secure the machine to the floor).
- The machine can be moved by forklift by inserting the forks in the rectangular "tunnels" in the base assembly at either end, running through, front to rear.

Selecting a Location

When selecting the location for the machine, there are a few considerations that will make the neighborhood more comfortable for all. Probably most important is open access to all areas around the machine so regular inspection of the machine and utilities is available. The area should be dry and have good ventilation, and the floor should be reasonably flat, especially if a bar feed may be a consideration.

The facilities / utilities required for the machine are: 120 VAC, single phase power @ 5 amps, 3 phase power of 230 VAC @ 45 amps or 460 VAC @ 25 amps and clean dry compressed air at 80 psig minimum, approximately 10 cfm, with no air tools.

A solid earth ground to a ground stake or reliable earth ground such as metal plumbing or construction metal in solid ground is required for a frame (chassis) ground to the machine. This earth ground must have a standing potential of less than 1VAC to a qualified earth ground point when in full operation.

Leveling The Machine

After completing the previous sections, the machine is free of shipping damage, the shipment is complete and the machine has been placed in an appropriate location, with the required facilities and utilities at hand. Assuming these conditions, continue with the set-up and start-up as follows:

- The machine has a flat bottom, and most floors are not especially flat. Therefore, it will probably be necessary to "shim" a couple of corners of the machine to make sure it is stable. It may also be wise to use some sort of adhesive, such as RTV, to assure the "shims" stay in place over time.
- If the machine is to be secured to the floor, the same hold down brackets that were used to secure the machine to the skid are intended for this purpose.
- If the machine is to be interfaced to a barfeed, check with the barfeed requirements for leveling and level the machine to the same tolerances to assure trouble free interfacing.
- A Sheet metal "Environmental tray" is provided for the machine to sit in. Place this on the floor first and using the leveling pads and anti-vibration pads, level and bolt down the machine.

Machine floor layout

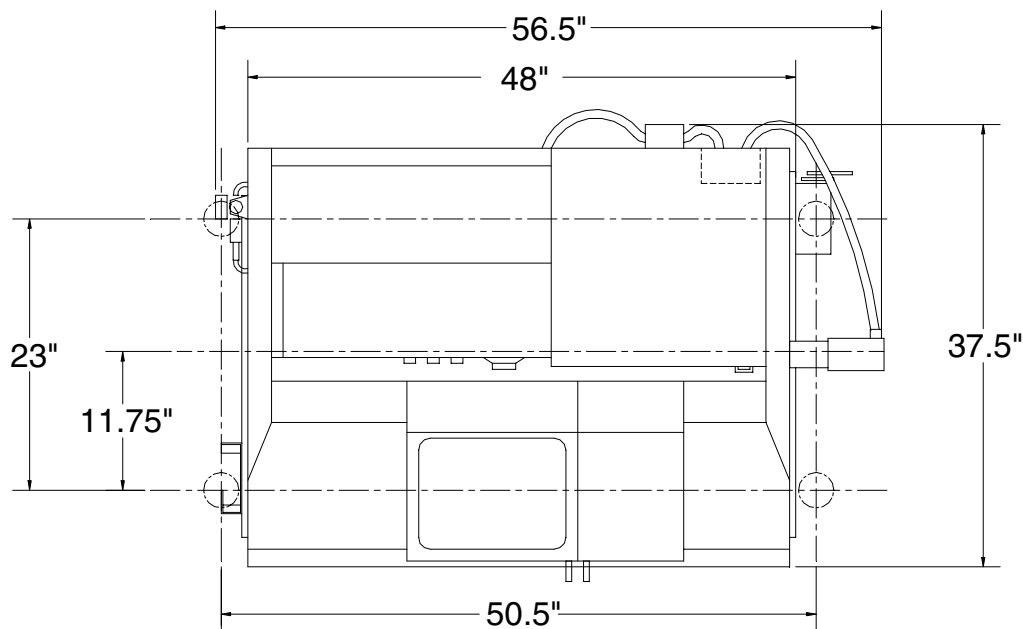

Footprint dimensions (fig2.1)

The basic machine hold down bolts are located on a 23"x50.5" footprint. The lower left hole is 3"x3" from the main frame corner.

Connecting The Machine

Connecting the Utilities

There are three **utility** connections required for the machine, they are:

- Three phase AC Power of 208 or 230 VAC (or optional 460 VAC)
- Single phase AC Power of 117 VAC (standard "wall outlet" power)
- A ground stake or solid earth ground from a non-electrical component.

There is one **facility** requirement. It is:

- clean, dry compressed air at 80 to 120 psig, with a volume of about 10 cfm , average, for a machine with no air tools.

For a machine with air tools, a volume of 25cfm is recommended.

Connecting the Power and Air

- Locate the safety switch (disconnect box) on the right end of the machine and make sure it is turned **OFF**, (handle down). Following the local electrical codes, construct the three phase power service to the safety switch. The three phase power should be routed through a **45 amp, three phase, ganged breaker**.
- After making sure the circuit breaker is **OFF**, connect the three phase power and earth ground conductors to the safety switch fuse lugs and ground buss respectively. Leave the safety switch turned **OFF**.
- Following the local electrical codes, bring a single phase, 5 amp, 117 VAC, 3 wire power service to the machine. Whether the "extension" power cord can be used or if a hard connection is required by code, we recommend that the noise filter input receptacle be used to provide the maximum noise isolation. Do **not** energize the machine at this time.
- Plumb as necessary, in compliance with local codes, to provide clean, dry, compressed air to the separator / filter air input at the quick connect fitting. The air should be between 80 and 120 psig with a volume capacity of 10 cfm, average. Do **not** supply air at this time.

Testing the Connections

Apply air to the air connection. Check for leaks at this time.

Plug in the 110volt connection on the Fagor controlled machines.

Press the Control On button. The Fagor equipped machines controls will power up. If they do not check the power supply for any interruption or cable damage.

Switch on the main wall breaker to the machine, and switch on the machine breaker on the right of the machine.

The 220 volt supply is only required for the spindle and coolant pump on Fagor controlled machines.

Fanuc controlled machines have an internal power supply to the control.

Press the control on button on the Fanuc equipped machines, the control and servos will power up.

Phase testing the Machine

Phase test on a Fagor 8025T

The easiest way to test phase is with the coolant pump rotation. Remove the 4 buttonhead screws on the left side of the machine and remove the panel. The coolant pump is located on the floor of the machine. The top of the pump has a plastic window, the impeller shaft has a dot on the top of the shaft, and the housing has an arrow cast into the top face. When the pump rotates the dot will spin and the direction of the shaft can be seen with the movement of the dot. If the movement is opposite to the arrow, Power down the 3 phase supply and reverse any 2 wires on the 3 phase breaker.

To activate the pump press this sequence of buttons.

Power On (wait for the display to show passed)

- Check that the emergency stop button is not depressed.
- Check that coolant switch is set to automatic.

On the control panel key in this sequence:

- Op Mode,
- 5(jog)
- M8(on keypad)
- Cycle start (green button on control)

The pump will rotate now. To stop pump rotation turn coolant switch to off.

Phase test on a Fagor 8050T

Power On (wait for the display to show the Upgrade start screen)

- Check that the emergency stop button is not depressed.
- Check that coolant switch is set to automatic.

On the control panel key in this sequence:

- Main Menu,
- F4(MDI)
- M8(on keypad)
- Cycle start (green button on control)

The pump will rotate now. To stop pump rotation turn coolant switch to off.

Other connections

If a barfeed is to be connected please refer to the connection information supplied with the bar feed.

Please refer to the section on live tooling for information on this subject.

Connecting the Fagor Controller to a Personal Computer (PC)

RS232 Connections

Data connection port

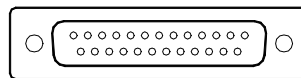

RS232

The control can be linked to a separate computer, so that programs, parameters, and offsets can be sent and received. This connection is through the DB25 connector on the rear side of the control box.

Parameter Configuration

The standard machine set up :

Description	Value	Parameter value
Baud rate	9600	P000 = 9600
# of bits	8	P001 = 8
Parity	No	P002 = 0
Stop bits	1	P003 = 1

Cable Wiring

The cable configuration is shown below.

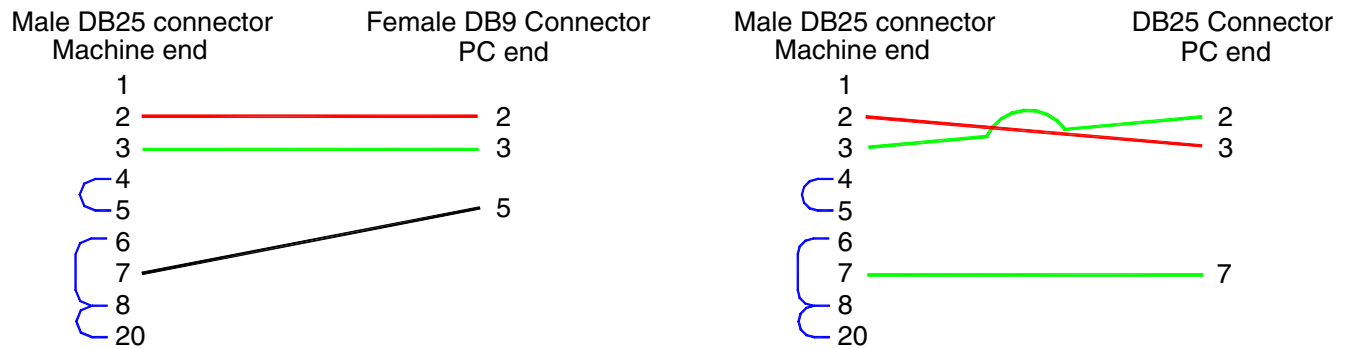

The cable requires a male connector for the machine end, see your computer port for the correct type of connector at the PC end.(Com port)

Programming Considerations

The program **must** begin with a % sign followed by a 5 digit part program number and the program must end with either:

an <EOT> (ASCII 4) character

or <ESC> (ASCII 27) character

or 20 <NUL> (ASCII 0) characters.

Example:

```
%12345 <LF>  
N10 G00 X0 <LF>  
N20 X1.5 <LF>  
N30 M30 <LF>  
<EOT>
```

Most commercial software allows the addition of ASCII codes on the end of file transmissions. Please see your software vendor for specific instructions.

Please refer to section 8 (Fagor 8025 operation) for sending and receiving programs.

Machine Connection locations

Locating the utility connection locations

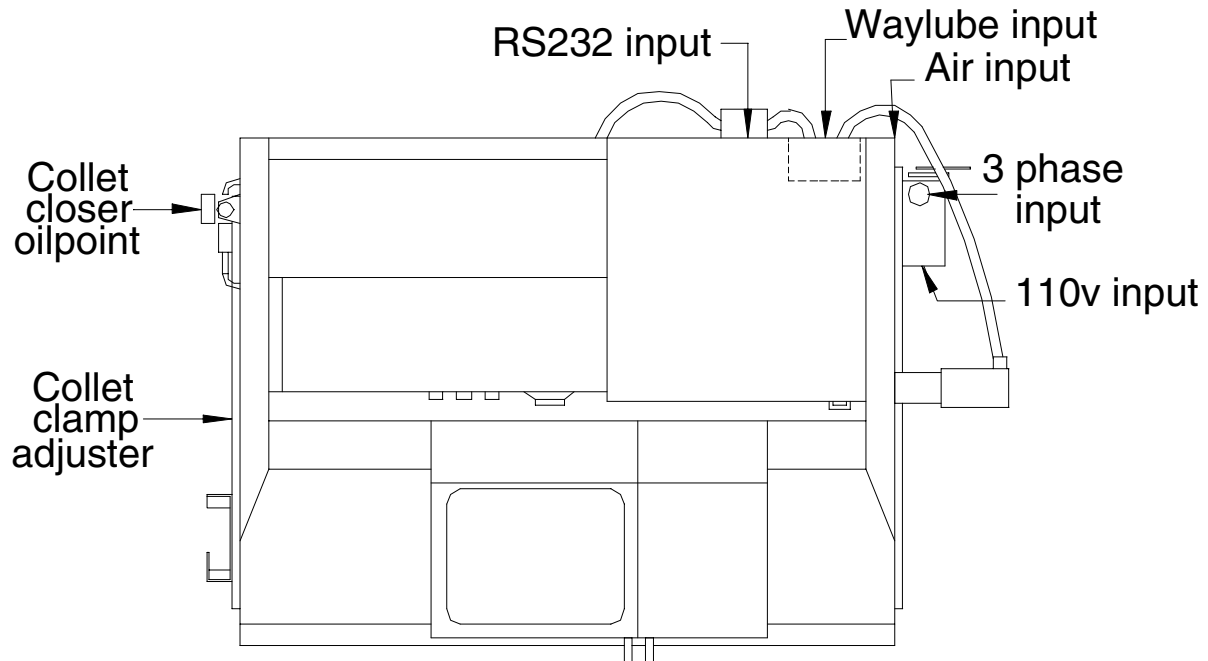

Machine top view (fig 2.2)

Collet clamp adjuster

The collet clamp adjuster controls the grip pressure for the drawbar. The range of adjustment is 20PSI to 110PSI.

Collet closer oil point

The collet closer oil point is only fitted to Dunham equipped machines. See the drawbar section of this manual for adjustment.

Air input

The air input is for a quick disconnect fitting.

Lubrication Comparison chart

Waylube System		Oiler for Air regulator	
1	Mobile Vectra 2	1	Mobile D.T.E. Oil Light
2	Esso Febris K-53	2	Esso Teresso 33
3	Sun Sunoco Waylube 80	3	Sun Sunvis 916
4	Shell Tona 33	4	Shell Turbo oil 32
5	BP Energol HP-20-C	5	BP Energol HP32

Section 3

Drawbar actuators

Drawbar actuator

Description

There are 2 air powered rotor actuators available, each operates at speeds up to 4500 RPM, even when powered with maximum air pressure. Special consideration has been given to enhance their durability; this includes hardened wear surfaces, complete sealing of rotating components, and urethane wipers. The bearings are shielded, and the draw tube mount acts as a seal.

The Dunham actuator requires an air/oil lubrication system that is located on the left panel of the machine.

The Powerhold actuator is sealed for life and requires no maintenance.

Both spindles are sealed for life and require no maintenance.

The air actuator is designed to mount to rotating devices, most commonly spindles. The unit will provide a push or pull force capable of opening or closing collets, fixtures, and short stroke power chucks.

- Clamping pressure can be adjusted using the air gage on the left side panel and its adjuster.
- Unclamp pressure is the supplied line pressure and cannot be adjusted.

Changing Dunham collets

The Dunham drawbar uses a threaded ring that screws into the rear of the drawbar.

To change a collet follow these steps:

1. This ring is removed from the spindle using the supplied wrench, The thread is right-handed so turn the wrench counterclockwise, exposing the actuating drawbar.
2. Using the same wrench turn the drawbar counterclockwise to unscrew the collet from the drawbar. The collet cannot rotate as it is keyed to the spindle.
3. Change the collet size in the spindle and thread the drawbar onto the collet. (Turn clockwise)
4. Replace the locking ring, and tighten.

Changing Powerhold collets

The Powerhold drawbar uses a spring loaded keyed hollow shaft that is retained by a locator ring on the rear of the drawbar. This requires no tool to change collets.

To change a collet follow these steps:

1. Pull the red knurled spring loaded shaft towards the side panel, The thread is right-handed so turn the shaft counterclockwise. The collet will unscrew as it is keyed to the spindle.
2. Change the collet size in the spindle and pull the shaft out and turn clockwise onto the collet.

Drawbar Operating Instructions

How to control the holding force

By using the regulator and gauge, start with air pressure of 60 lbs.; increase pressure gradually until part is held sufficiently for machining operation.

The air actuator permits even gripping pressure although workpiece may have diameter variation. Holding force can be adjusted for any type of machining by increasing or decreasing the air pressure.

Attached Oil-Mist Lubrication (Dunham spindle only)

The attached oil mister is to provide a regular flow of lubricant to the collet closer assembly, keep this oil level topped off after each day to ensure an adequate supply of lubricant.

A shut off valve **MUST** be used to turn off air supplied to oil-mist assembly when not in use. Failure to use this lubrication will result in unit failure.

Adjust the flow of oil to : Air pressure 12 to 15 PSIG

Flow 1 drop per 60-90 seconds

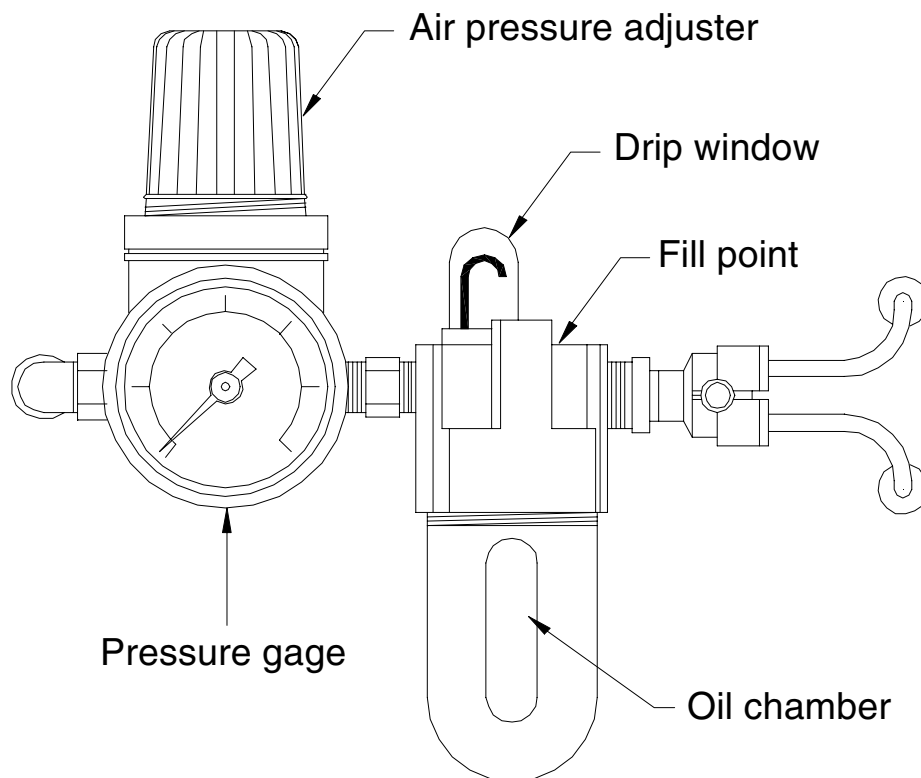

Oiler for drawbar actuator (Fig3.1)

Section 4

Fagor 8025 TG Screen Layout

Screen and keyboard layout

The control is laid out in a simple to understand format comprised of:

1. Screen
2. Alpha keypad
3. Numeric keypad
4. Cursor keys
5. Function keys
6. Jog keys
7. Spindle keys
8. Cycle Start and Feed Hold keys
9. Reset key
10. Editing keys
11. Op Mode Key
12. Feedrate override knob

The basic layout of the control is shown below.

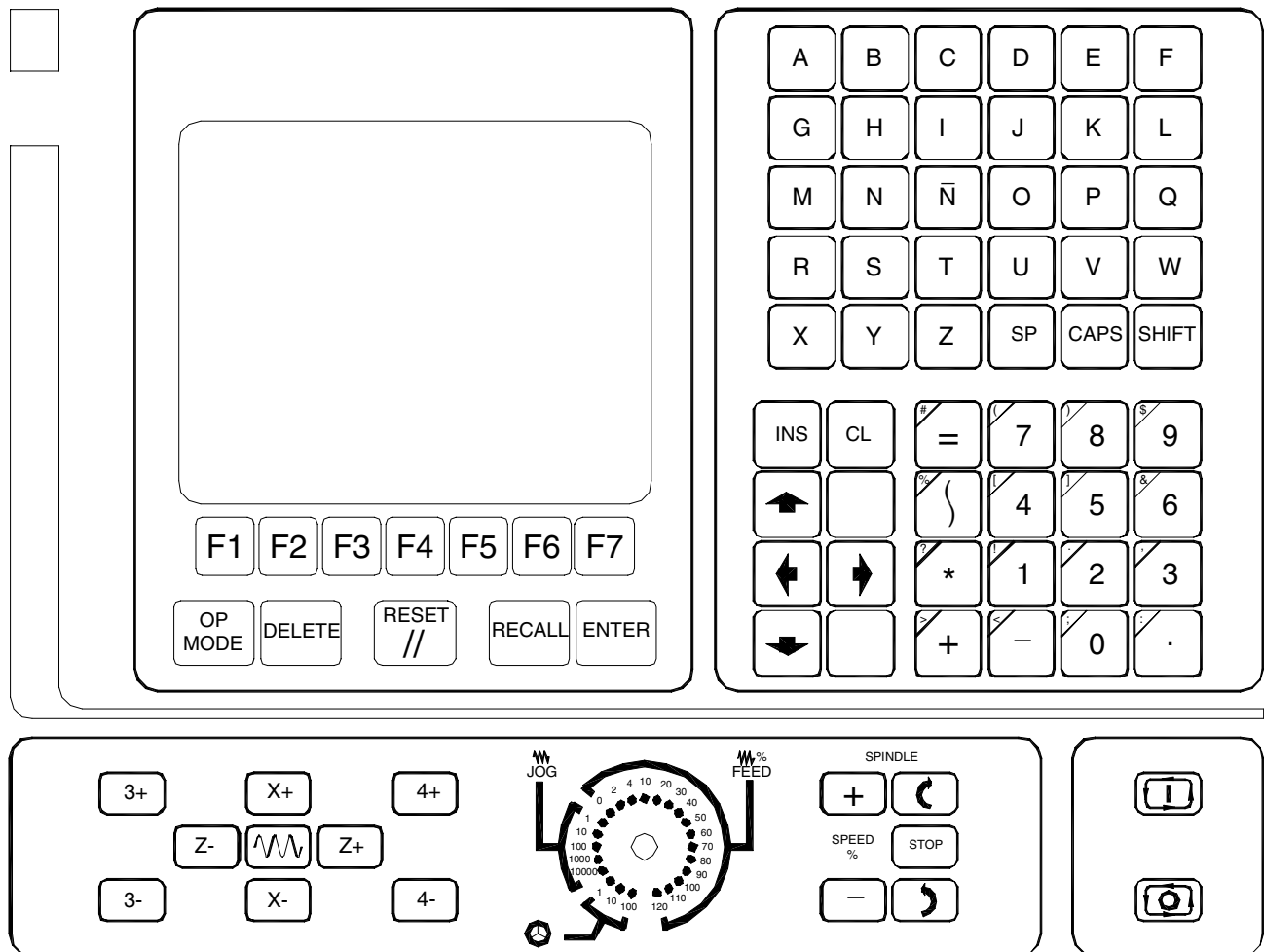

Control panel layout(Fig4.1)

The following section will cover each area of the control.

Screen and keyboard layout

Screen

The screen area changes depending on the OP MODE selected. Each OP MODE can display a number of pages and the cursor up and down keys can access these pages.(see Function keys)

Alpha keypad

The Alpha keypad is used to input programs and messages and select axes for the control.

The 3 keys at the bottom right are used for messages and are described below.

SP Space key for adding spaces to messages

CAPS Capitals key for using upper and lower case letters in messages.

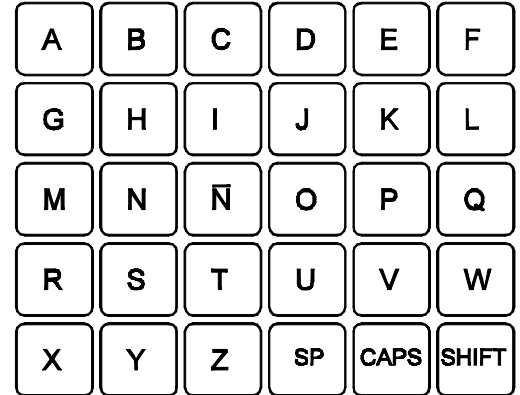

SHIFT Shift key is for accessing the special function keys on the numeric keypad.(see numeric keypad below).

Numeric keypad

The numeric keypad is used to enter numbers and symbols into the programs, and to enter information when setting tools or offsetting. Or any time that a number is required by the control for an operation.

To access the special symbols on the upper right of the keys press the **SHIFT** key on the alpha keypad,

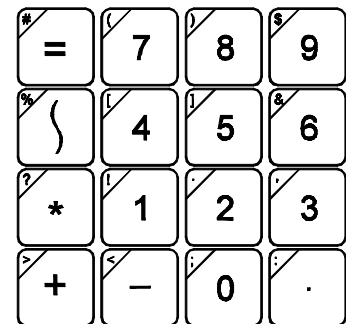

Cursor keypad

This area is used to scroll through programs or sections of the screen. When editing a program the left and right keys move you through the program line. The 2 keys at the top are used for editing and are grouped in this area for ease of access.

INS This key is the **INSERT** key. Pressing this key in edit mode gives a highlighted cursor and moves all existing information to the right as you input new information to the left. A complete explanation is include in the section, How to edit a program.

CL The **CLEAR** key removes information. Place the cursor on the code you wish to remove and press CL.

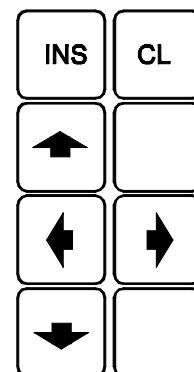

Screen and keyboard layout

Function Keys

These keys provide different screen depending on the **OP MODE** selection



Jog Keys

The jog keys move the machine in jog mode X moves the slide across the spindle and Z moves the slide towards or away from the spindle. The speed of movement can be controlled by the position of the jog override knob.

The X & Z axis keys reflect the movement Directions of each axis.

The 3 & 4 keys are for the extra possible axes. On the standard configuration machine these keys are not functional.

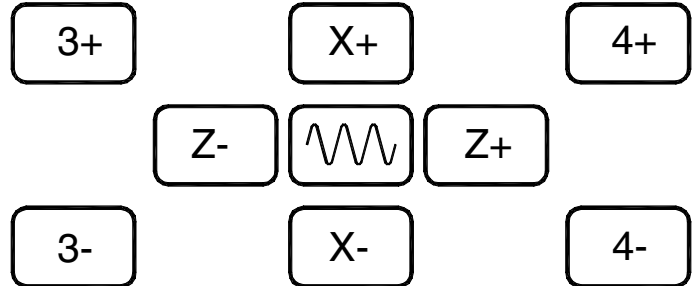

Spindle Keys

The spindle keys start and stop the spindle in either a clockwise or counter-clockwise direction. The percentage override range is 50% to 120% of programmed speed.

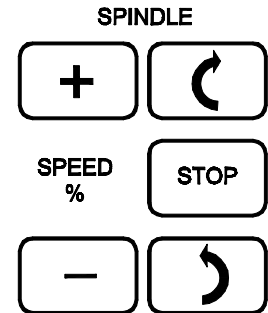

Cycle start and Feed Hold keys

The Cycle start (upper key) starts the machine cycle in Automatic and dry run modes, and is used to activate tool initiation in setting mode.

The Feed Hold key (lower key) halts operation of the control and stops axis motion.

When the Feed Hold is pressed the screen flashes "Interrupted"

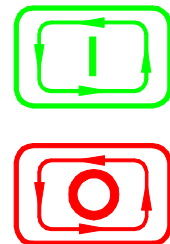

Reset key

The Reset key sets any mode in operation to an off status.

When the Feed Hold is pressed the screen flashes "Interrupted" to end the cycle press **RESET** twice.

To reset the control after changing parameters press the reset key 3 times.



Screen and keyboard layout

Op Mode key

The Op Mode key return the original screen displaying the 10 choices for the control.

A rectangular button with rounded corners containing the text "OP MODE" in bold, uppercase letters.

Editing keys.

DELETE The Delete key can be used to delete programs in the program directory screen and to clear the time and part counter in the Automatic (subroutine) screen.

In editing mode this key can be used to delete code lines

A rectangular button with rounded corners containing the text "DELETE" in bold, uppercase letters.

RECALL The Recall key is used to Recall a block # or program # in Automatic mode, To recall a tool or G53-G59 offset in tool offset mode or a block in editing mode.

A rectangular button with rounded corners containing the text "RECALL" in bold, uppercase letters.

ENTER The Enter key is used to accept any information that will be written to the control memory.

A rectangular button with rounded corners containing the text "ENTER" in bold, uppercase letters.

Feedrate / Jog Override knob

The jog override knob has a number of settings when moving the machine slides manually.

Feedrate override

The feedrate override section (0-100%) is only enabled when in automatic, dry run, and jog mode.

This mode allows the operator to slow down or stop the slide motion, including rapid moves.

The operator can safely run a program and check the feedrates for the program, and easily determine how much the program feedrates need to be adjusted to complete the parts safely and with the correct finishes.

This also overrides the rapid traverse speeds, when running a program.

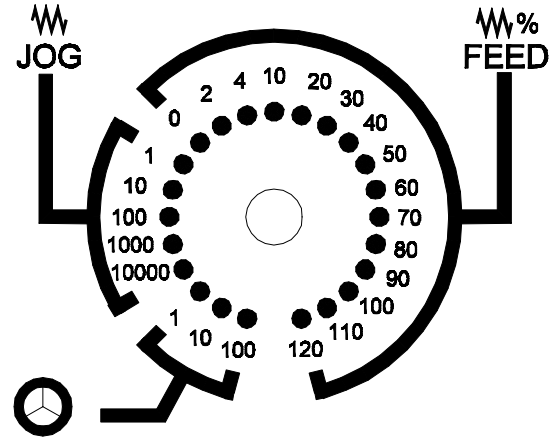

Jog override

The jog mode override is used in jog, and teach in mode. Each position allow the machine to be jogged that amount. in inch mode each press of the axis jog button moves the selected axis this amount:

Switch location	X axis	Z axis
1	0.0002"	0.0001"
10	0.0020"	0.0010"
100	0.0200"	0.0100"
1000	0.2000"	0.1000"
10000	2.0000"	1.0000"

Warning:

Be very careful when close to the collet or chuck if 10000 is selected and you are within 1" of the collet or chuck and Z- is pressed a collision is likely. An operator will not be able to stop the machine in time to avoid a collision.

Handle override

The handle mode allows the axes to be moved by using the manual pulse generator(MPG).

Turn the knob to this section and press the X or Z on the alpha key pad(to the right of the screen)

The axis will display in reverse video(Highlighted) on the screen. Each position represents a different amount of movement.

The amount of movement is determined by the parameters in the control and the axis drives.

Normally the amounts equal:

1	=0.0002"
10	=0.0020"
100	=0.0200"

Secondary control panel

The 3 switches on the left of the controller are for coolant, collet, cycle start and handle jog operation.

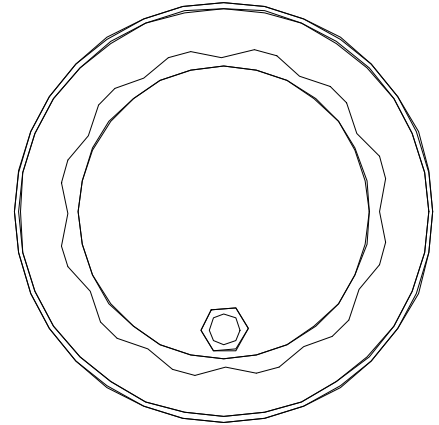
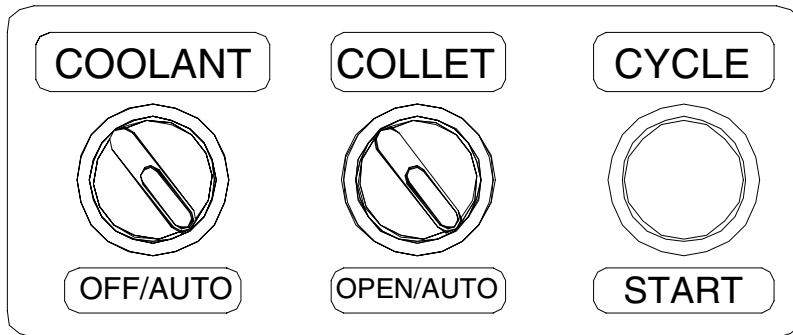

Coolant switch

The coolant switch controls whether the coolant pump is activated when programmed, if it is set in the OFF position, the coolant pump will not activate, when an M08 code is commanded.

If the switch is in the AUTO position the coolant will be activated by a M08 and deactivated by a M09.

Collet switch

The collet switch controls whether the collet is activated when programmed, if it is set in the OPEN position, the collet will open, when in AUTO mode the collet will close and an M10 will open the collet. and an M11 will close the collet.

Cycle Start switch

The CYCLE START button controls the machine when in automatic or single block mode, This button activates the controller and program cycle will start.

Manual pulse generator

This handle will move the X or Z axis of the machine when in handle mode.

Please refer to the prior page for explanations of use and axis and amount selection, for this handle.

Machines with indexing spindles

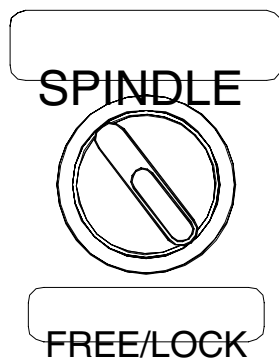

This switch disengages the spindle lock. In Free mode the spindle cannot be programmed to run.

If a spindle command does not start the spindle in a program check the position of this switch.

Section 5

CNC Programming

Coordinate Types (Cartesian)

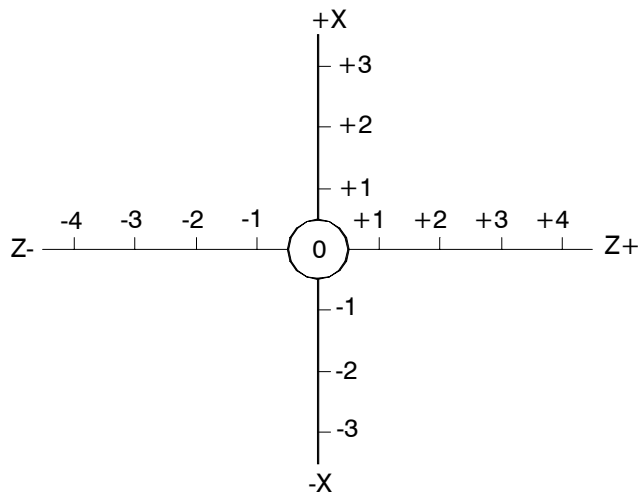

G90 Absolute system (Fig 5.1)

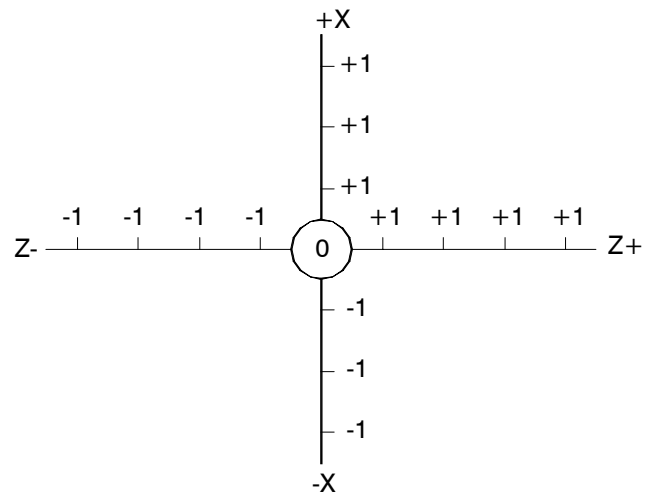

G91 Incremental system (Fig 5.2)

G90 Absolute Position

Absolute positioning uses a known fixed zero point as a reference for the commanded positions.

A move from X0 Z0 of X1.0 Z1.0 would move the tool to position X1.0 Z1.0, if a command of X3.0 Z-2.0 is made the tool will move to the grid position X3.0 Z-2.0. This is the normal method of programming and directly relates to most machine part prints.

The grid has a specific location for any point and the X and Z locations call these points.

G91 Incremental Position

Incremental coordinates use the last position of movement to define the next move.

If a move from X0 Z0 of X1.0 Z1.0 is commanded, the new coordinate would be X1.0 Z1.0, if the next move was X2.0 Z1.0 the new coordinate would be X3.0 Z2.0(X2.0+X1.0)(Z1.0+Z1.0).

As you can see this uses the last position as the next position zero point.

This option is very useful when programming the same feature on a part a number of times. (grooves) or a grid of holes when using a live tool, and a sub program is called. You would not have to define a new zero position, as each call moved from the last absolute commanded position.

Radius and Diameter Programming

A program can be created using either Radius or Diameter co-ordinates but cannot be switched between types in a program. The machine parameters must be set for the type of programming method required.

The most common method of programming a lathe is in diameter mode, and this method is the one that all explanations will be given in.

The most basic difference is that in Radius mode a required part diameter of 1.0" would be called out as X.5

In Diameter mode the same part dimension would be called as X1.0

As you can see, this will make your programs much easier to read and trouble shoot.

In some of the canned cycles values are requested as Radius values, This is to assist in ease of programming.

Machine Coordinate System

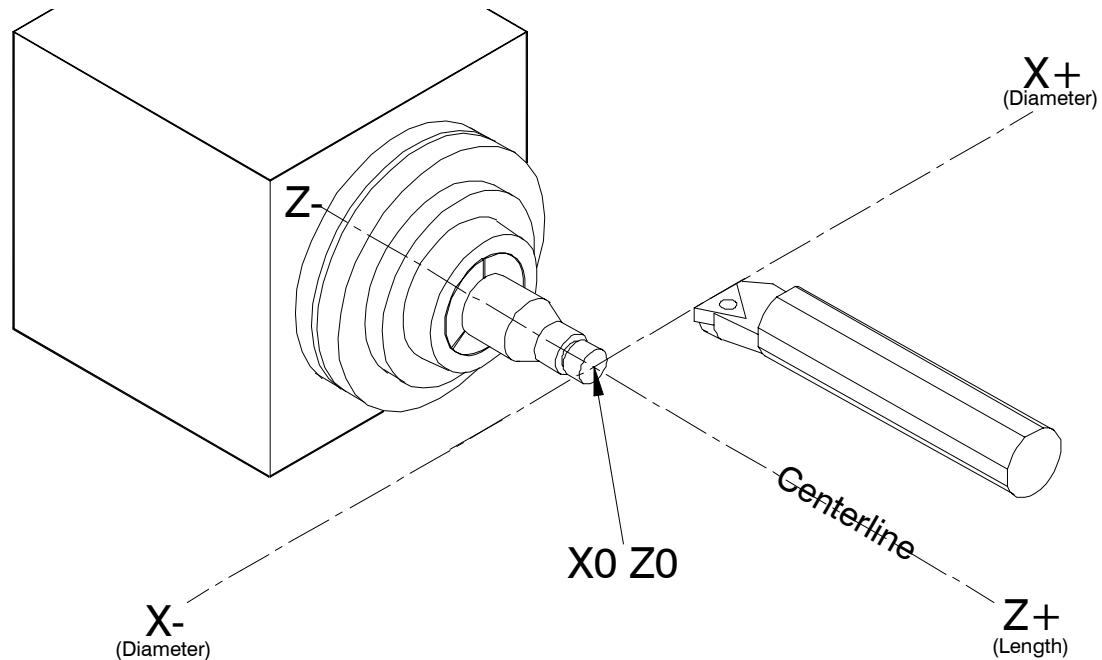

Table axis reference system(Fig 5.3)

Axis direction

The axis direction on a lathe is controlled by a variety of parameters in the controller. These parameters can be set to allow different axis directions. The most often changed axis is the X direction. The Z axis direction is normally not changed, and its movement is generally as shown in fig 5.3.

Tool Hand directions

When using a gang tooled lathe both left and right handed tools can be used to machine parts. The advantage of this is the ability to set tools so that fast cycles can be achieved. Most tools used on a gang tooled lathe are boring bars as this allows more tools on the tool plate, and the ability to adjust the length of the tool to suit the job being machined.

The COMPACT GT27 is setup so that a right handed boring bar when located with the insert face up, is programmed with a positive X axis co-ordinate. Offsetting the tool for wear is correct (X+ offset and the diameter increases.)

Drilling takes place on the X axis centerline and is unaffected by the axis direction. Most live tools are set up at the top of the table and again allow positive X axis values for positive offsets.

When a program example is given it will assume this format. When threading any special needs will be explained, with examples.

Construction Of The Program

After the proper coordinates have been assigned to the drawing, the programming consists of turning on or off the proper accessories and sending the tools on the path you have determined necessary to complete the part.

A rough layout of the tools on the slide or on a piece of paper should be completed before you start to write the program. Take into consideration the length of the tools and the proximity of one tool in respect to another while it is cutting the parts. Always leave room for the various tools. After a tool is clear of the workpiece the exit move should always be in the Z+ direction to avoid crashing other tools in line on the slide. Determine the tool number for each tool that you are going to use then you are ready to start writing the program.

Table Tooling Layout

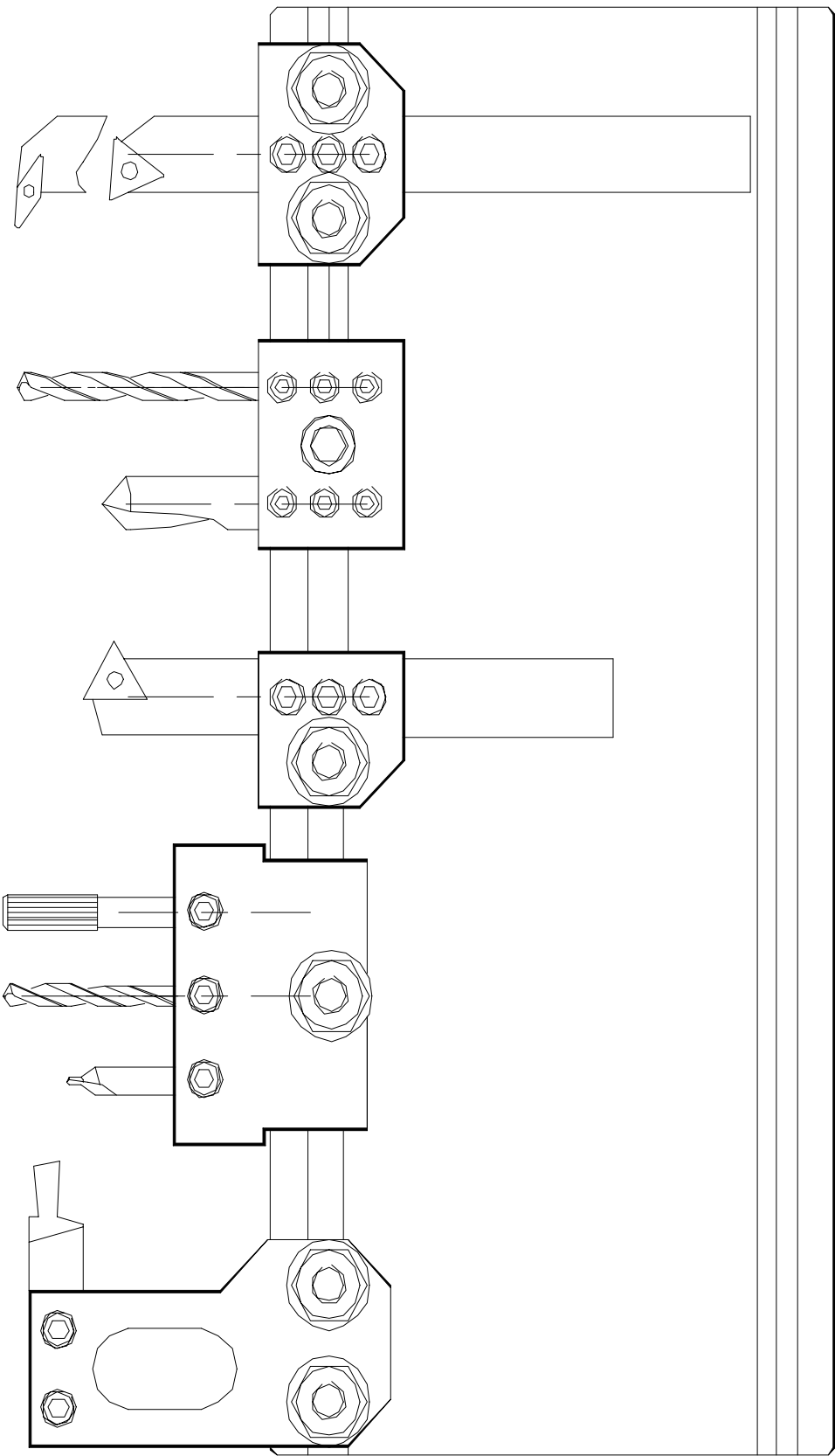

Table layout(Fig 5.4)

The tooling plate shown is displayed to demonstrate a possible layout of tools. This layout allows for a cutoff tool ,Center drill, Drill, Reamer, External thread tool, Large center drill, drill, and turning bar.

M codes

M codes are commands that turn on or off mechanical switches, these can be Relays or programmed operations.

M code list

- M00 Program hold**
- M01 Optional program stop**
- M03 Spindle forward**
- M04 Spindle reverse**
- M05 Spindle stop**
- M08 Coolant on**
- M09 Coolant off**
- M10 Collet open**
- M11 Collet close**
- M19 Orientate spindle**
- M20 Air On (live tool option)**
- M21 Air Off (live tool option)**
- M30 Program end (rewind)**
- M60 Parts catcher open**
- M61 Parts catcher closed**

M code Descriptions

M00 Program Stop

The M00 code is used to stop operation of a program. It causes the spindle and coolant to be switched off. A cycle start will resume operation of the program from the cursor position.

M01 Optional Program Stop

The M01 code is used to stop operation of the program selectively by activating the optional stop button. The spindle and coolant are not switched off. A cycle start will resume operation of the program from the cursor position.

M03 Spindle Forward

The M03 code will start the spindle in a clockwise direction at the programmed spindle speed. The machine waits until the spindle reaches a percentage of the programmed speed. Direction of the spindle is determined by standing at the left side of the machine and looking towards the tool slide M03 is considered clockwise.

M04 Spindle Reverse

The M04 code will start the spindle in a counter clockwise direction at the programmed spindle speed. The machine waits until the spindle reaches a percentage of the programmed speed. Direction of the spindle is determined by standing at the left side of the machine and looking towards the tool slide M04 is considered counter clockwise.

Miscellaneous Functions

M05 Spindle Stop

The M05 code stops the spindle.

M08 Flood Coolant On

The M08 code will start the main coolant pump. This code is activated at the end of a block and if used in a movement block will not activate until the end of the commanded move.

M09 Coolant Off

The M09 code switches off the main coolant pump.

M10 Collet Close

The M10 code is used to retract the draw bar into the spindle(close the collet)

M11 Collet Open

The M11 code will advance the drawbar from the spindle.(open the collet)

M19 Index spindle(Optional)

The M19 code will set the spindle controller in index mode, specify an absolute angle that the spindle is to index to. Example M19 S90(see Live Tools for a further explanation).

M20 Air blow On

This code activates the air solenoid on the live tool.

M21 Air blow Off

This code de-activates the air solenoid stopping the live tool.

M30 Program Rewind

The M30 code is used as a program end. It will stop the spindle and turn off the coolant.

The cursor will be reset to the beginning of the program.

M60 Parts Catcher open

The M60 code is used to activate the parts catcher.

M61 Parts Catcher Closed

The M60 code is used to activate the parts catcher.

Preparatory Functions

G codes are the basic codes that command a CNC controller to move, or prepare the control for a type of move, or set the control in a mode to be able to interpret a method of operation.

Modal operation

The advantages of modal G codes is that you do not have to type or enter a repeated code on every line.

G00 X1. Z.1;	G00 X1. Z.1;
G01 Z0;	G01 Z0;
G01 X1.5 Z-.5;	X1.5 Z-.5;
G01 Z-2.;	Z-2.;
G00 X3. Z1.;	G00 X3. Z1.;

Both of these programs will operate exactly the same.

G00 or G0 Type format

The format for a G code can be G00 or G0 both will work with the controls.

How to use The following section of the manual

The Following G code descriptions are a brief overview of some but not all of the 8025TG capabilities.

This manual is not meant as a replacement of the Fagor 8025TG programming manual, but a reference, to provide simple explanations to the most commonly used features.

The Explanations and examples are written in inch co-ordinates for the United States.

All examples are tested for accuracy, But Upgrade Technologies Inc. accepts no responsibility for machine or tooling crashes caused by miss setup or application by any machine operator.

Movement Commands

G00 Rapid Travel

This code causes machine motion to occur at the maximum traverse rate of the machine tool.

When only one axis is programmed the move will be a straight line, when both axis move simultaneously, each axis moves at its maximum speed, until one axis end point arrives at the programmed location. In the case of an X and Z rapid move, the axes would move along a 45 degree angle until either axis reached its programmed location. The other axis would continue to its programmed location.

In the figure below the left example shows a rapid move when the X axis move is greater than the Z axis move.

The figure on the right shows a rapid move when the Z axis move is greater than the X axis move.

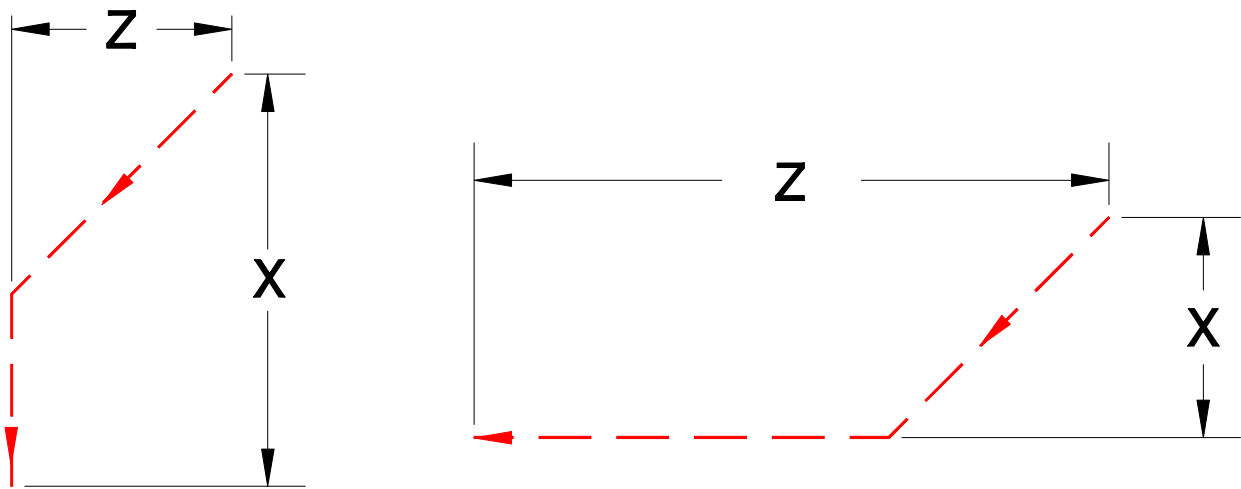

Rapid moves in X & Z that are unequal(fig 5.5)

G01 Linear Interpolation

A mode of movement in which, one or two axes move simultaneously to the programmed end point. The programmed feed rate in moves with X or Z motion are maintained along the line determined by the X and Z dimension words.

A single axis move moves the machine in one direction only. Either X or Z. These moves are considered axis parallel. When a taper is to be programmed both axis must be commanded.

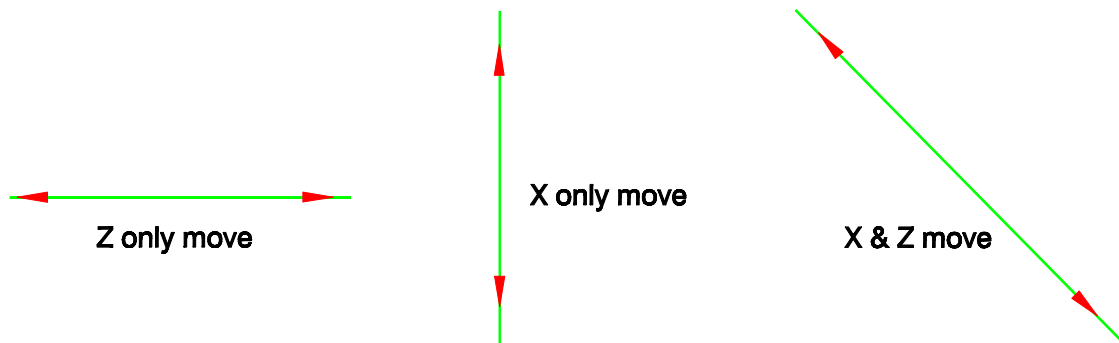

G1 moves(fig 5.6)

Movement Commands

G02 Circular Interpolation Arc Clockwise

A clockwise arc generated by the coordinated motion of two axes. The arc is defined as G2 when the tool motion, relative to the work piece, is clockwise. An arc is defined with the start point, the end point, the incremental distance from the start point to the center of the arc (I and K), and the direction of the arc, or an R value equal to the required radius.

In the example to the left either an R value or an I value both equal to the radius would be programmed, K is zero and it is recommended that it is included in the line.

In the example in the middle either an R value or a K value both equal to the radius would be programmed, I is zero and it is recommended that it is included in the line.

In the example to the right either an R value, or both I & K values are required.

Remember I & K values are distances from the start position to the center of the radius and can be positive or negative.

In G68 roughing cycles arcs must be programming using I & K

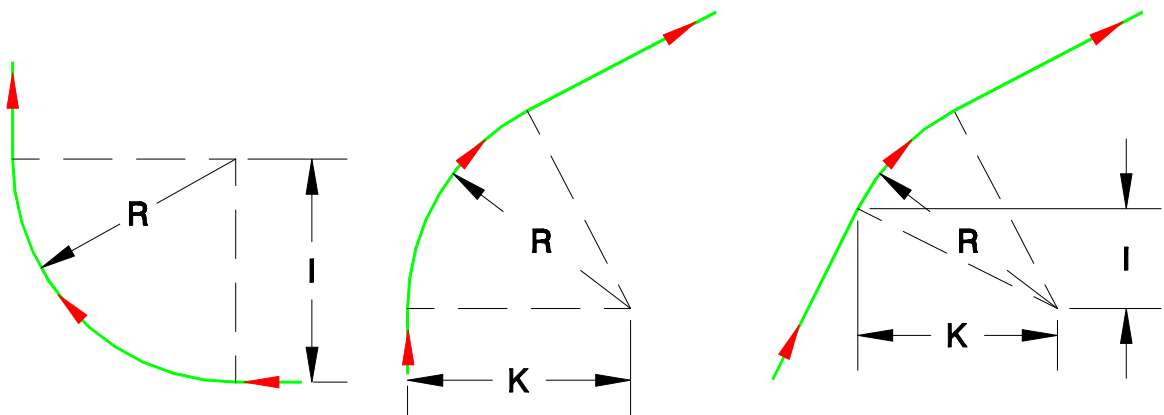

G2 Moves(fig 5.7)

Difference's between R and I & K values when programming arcs.

Example of a 1/8" radius from the X0 Z0 centerline

N30 G2 X.25 Z-.125 R.125 or N30 G2 X.25 Z-.125 I0 K-.125

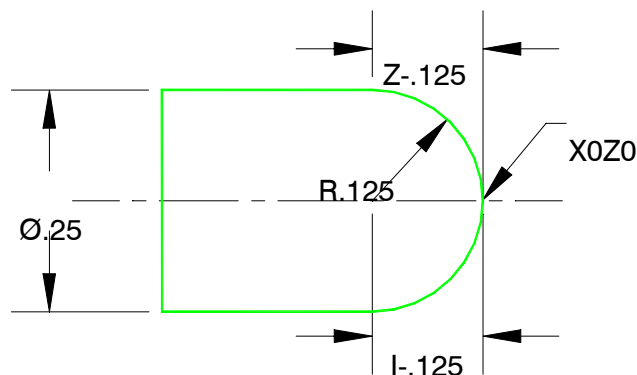

I&K or R values(fig 5.8)

Note: Arc centers are defined using I as the X axis plane and K as the Z axis plane.

arc centers are always incremental from the start point of the arc.

Movement Commands

G03 Circular Interpolation Arc Counterclockwise

A counterclockwise arc generated by the coordinated motion of two axes. The arc is defined as G3 when the tool motion, relative to the work piece, is counterclockwise. An arc is defined with the start point, the end point, the distance from the start point to the center of the arc (I and K), and the direction of the arc, or an R value equal to the required radius. The examples in G2 can be used to explain the I, K and R values.

Directions when programming arcs.

When programming external or internal arcs the basic rule of clockwise and counterclockwise always applies.

The same arc can be programmed with either G02 or G03 depending on the direction of the tool motion.

Grooving is a good example of this.

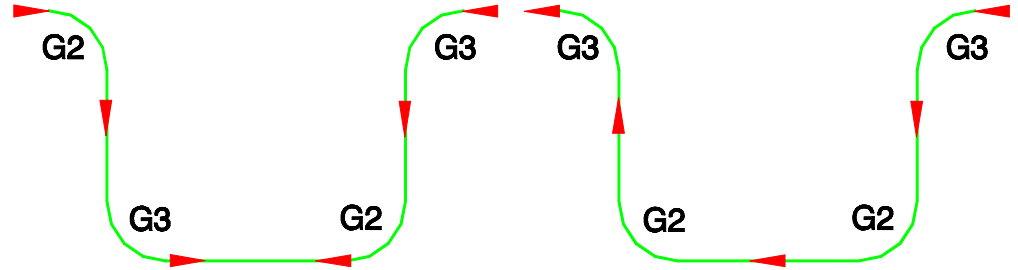

Different side approach direction Same direction approach (Fig5.9)

G04 Dwell

A timed delay of programmed duration. The time in seconds is coded with the K word. For example, G4 K2.5 is a time delay equal to 2.5 seconds.

G05 Block Deceleration checking off

Corner rounding is proportionate to speed. The faster the feed, the bigger the error at a change of direction will be. This is used to decrease the overall cycle time, by reducing error checking when accuracy is not need. (roughing, tool change movements etc.)

G07 Block Deceleration checking on

This G code forces the control to check for accurate positioning and ensures that an end point is reached before the control allows a change of direction. This format is the machine default, and should be used for all accurate machining.

G25 Unconditional jump

This feature is very useful for cycling programs when bar feeding, and looping programs when using subroutines that are within the main program. See a full explanation on page 41 and 42.

G26-G29 Conditional jump

Please refer to the Fagor programming manual for a full explanation.

G36/G39 Automatic corner radius & chamfering

G36 is a radius at the end of the cut, G39 is a chamfer. this code saves programming time when specific radii or chamfers are desired. This can be used when non axis parallel moves are required.

Defining G2 or G3 and arc centers are not necessary to utilize this feature.

The format has to be as follows:

G1 G36 R?? X?? or Z?? or G1 G39 R?? X?? or Z??

If this format is not followed the control will not allow its input into a line. See page 43.

G37/G38 Tangential approach and exit

This code allows facing to centerline or approaching centerline without back-cutting to remove centerline dimples that are sometimes left on a face. Using the code saves programming time.

Movement Commands

G40/G41/G42 Tool nose radius compensation

These G codes allow the actual part profile to be entered as the program. Any variation in tool nose radius can be accommodated by editing the tool table for radius, rather than changing the program.

The main rules are that the proper tool location codes are installed on the tool offset page and that the entry and exit moves are at least double the radius value entered in the table.

See [Using and Calculating tool nose radius compensation](#) for a full explanation of these codes.

G51 Temporary offset

example: **G51 I.02 K0** (will shift X axis + .020) proceed with turning then call tool number Tx.x to cancel the offset. This is useful for taking a number of cuts around a profile using 1 sub profile.

G53-G59 Work co-ordinate offsets

These are position offsets for moving the tool offset table by a fixed amount. They can be used for cutting multiple parts.

If a part is to be turned around in the collet and have a 2nd operation completed, the G55 offset could be used to provide a 2nd Z zero location for the 2nd operation. Without changing the tool offsets used for the 1st operation.

This Section is reached by pressing: **OP MODE, 8, G**. Enter a # and press RECALL to edit the offset.

A positive offset moves the tool away from the spindle.

A negative offset moves the tool towards the spindle.

G70 Inch programming

Programming in inches. The machine is set-up in inch mode.

G71 Metric programming

Programming in millimeters. If you wish to program in millimeters, please refer to the parameter tables and change the machine co-ordinate system to metric.

G74 Home search

This code sends the programmed axis to its home position

G90 Absolute co-ordinates

This code is used for programming in the absolute program format.
(please see machine co-ordinates).

G91 Incremental co-ordinates

This code is used for programming in the incremental program format.
(please see machine co-ordinates).

G92 Maximum spindle speed clamping

This code is used for constant surface speed maximum RPM clamping.

If a surface speed of 600 SSFM(surface speed in feet per minute) is commanded for cutting but a maximum RPM of 1200RPM is required a G92 S1200 would be commanded on a line prior to the spindle speed command. (See G96)

Feedrate Control

G94 Feed Rate Specification IPM, MPPM

This mode allows the feed rate to be specified by Millimeters Per Minute or Inches Per Minute. Normally this is used when no spindle speed is active and machine motion has to be controllable (Not rapid). Such as bar feeding.

This method of programming is the recommended method when using a live tool. No decimal point is allowed.

F80 = 8 inches per minute
F800 = 80 inches per minute

Feed in inches per minute (G94)
(fig 5.11)

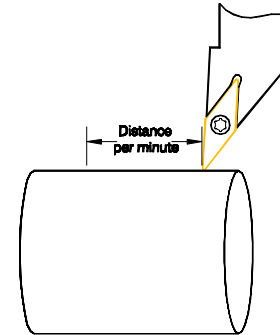

G95 Feed Rate Specification IPR, MPPR

This mode allows the feedrate to be controlled in relation to the commanded spindle speed.

The feedrate is based on feed per revolution (FPR)

In inch mode the feedrate would be programmed as :

F.002 (.002" per rev)

or in metric:

F.02 (.02mm per rev).

Feed per revolution (G95)
(fig 5.12)

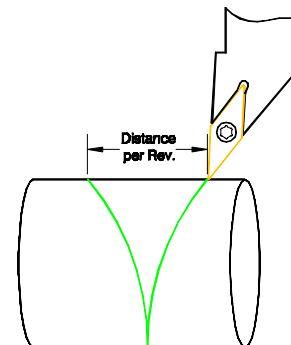

In order to program finer feedrates than the minimum allowed by G95, it may be necessary to switch to G94 and specify a small feed in Inch per minute, to achieve a similar slow feed rate.

Example: $3000\text{rpm} \times 0.15'' \text{ per minute} = 0.0001'' \text{ per rev}$

F Feed rate address

This code is used to control how fast or slow the machine executes an axis move, depending on the G code selected this code can be in inches per revolution or inches per minute.

Feedrates are modal commands and once an amount is commanded, that feed rate is active until a new feedrate is programmed. This number can be up to 4 decimal places (F.0001)

Normally in lathe programming the setting is for inches per revolution.

Example: N1 G1 X.5 Z-.1 F.002 = .002"/rev

N2 G1 X.5 Z-.1 F.010 = .010"/rev

Line N1 commands a feed of .002 inches per rev.

Line N2 commands a feed of .010 inches per rev., This feed rate is 5 times faster than line N1.

Spindle Commands

G96 Constant surface speed mode (CSS)

This code controls cutting speeds base on surface speed and diameter being cut.

A given surface speed will produce a variable RPM depending on the diameter programmed.

The example below demonstrates this:

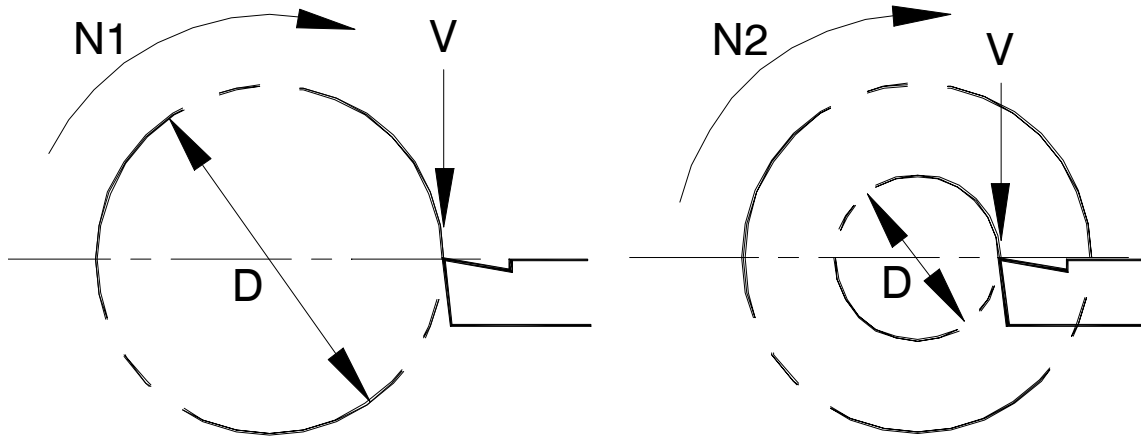

RPM based on surface speed (fig 5.10)

$$\text{RPM(N)} = \frac{\text{SSFM(V)} * 3.82}{\text{Work Diameter(D)}}$$

Given the same SSFM(V) 2 different diameters will give 2 different speeds in RPM

600 SSFM at a 2" diameter = 1146RPM

600 SSFM at a 1" diameter = 2292RPM

If a 2" part was to be faced to 1" diameter using CSS the machine would increase RPM from 1146RPM to 2292RPM gradually as the cut decreased in diameter.

If the same calculation is used on a .1 diameter you can see that the RPM exceeds the spindle capabilities of the machine.

$$\text{RPM} = \frac{\text{SSFM} * 3.82}{\text{Work Diameter}} \quad 600 \text{ SSFM at a .1" diameter} = 22,920 \text{ RPM}$$

This is the reason why a G92 code is required when using CSS

Example G92 S4500 (Max speed preset)
G96 S250 M3 (SSFM and Spindle On)

G97 Constant Revolution per minute mode

This code allows programming of RPM as a fixed amount such as for threading, drilling, reaming, etc.

Example: G97 S750 M3 (750RPM, spindle forward)

Spindle Orientation

Activating spindle orientation

To activate the spindle as a vector spindle capable of indexing issue a M19 to the control for each index you require. An S value is also required to specify where to index.

The 1st index is required to start initiation and may not be accurate.
After the 1st index call the position.

In this example 3 holes are to be drilled at 120 degrees to each other.
The 1st index on line N30 is a start initiation.

N50 calls the actual start location

In this example the drilling moves are located in a sub program at N1000 to N1025

G94 feed in inches per minute is programmed as no spindle speed is being used.

```
%00101
N00 G90 G94 T7.7 M8 (.068 Cross Drill)
N10 G00 X -.6
N20 Z.1
N30 M19 S15 (Home spindle)
N40 G01 Z -1.0 F250 (Index to 1st Position)
N50 M19 S60
N60 G25 N1000.1025 (Drill 1st hole)
N70 M19 S180
N90 G25 N1000.1025 (Drill 2nd hole)
N100 M19 S300
N120 G25 N1000.1025 (Drill 3rd hole)
N130 G00 Z2. M5
N140 M30
N1000 G01 X -.1 (Cross drill sub)
N1005 G01 X0 F20
N1010 G00 X -.1
N1015 X0
N1020 G01 X.1
N1025 G00 X -.6 F250(Safe index position)
```

To program a spindle movement with an axis movement required a full C axis spindle.

Other Addresses

I & K Incremental value for position of radius center point from start point.

See the explanation of I and K in G2 Circular interpolation.

N Block numbers

Every block must have a block number. The 8025 control automatically places block #'s on each new line. The standard numbers are in 10 as below.

N10 G90 G95 S2000 T2.2 M3 M8

N20 G92 S3500

N30 G96 S600

N40 G00 X2.

To insert a new number for a line press CL in editing mode without a line being edited.

Type the new block # and the extra code and press enter. This will add a new line at the correct position in the program

Example: N15 G55

N10 G90 G95 S2000 T2.2 M3 M8

N15 G55

N20 G92 S3500

N30 G96 S600

N40 G00 X2.

P Address

Each program uses a different 5 digit P value.

The canned cycles use a group of variables described by P1-P19.

R address

The R word is used for programming radius values in G2 and G3 and chamfer and radius values in G36-G39

S Spindle speed address

This a 4 digit number that is used to specify the spindle speed or surface speed required.

See G96 and G97 for specific details.

T Tool code

This a 2 digit number that is used to specify the tool. See using tool offsets.

X & Z Absolute addresses

These addresses command axis movement in absolute mode. This is the recommended style of programming. X is a diameter designation and Z is Linear.

Using Tool offsets

T Tool number address

This a number between T1.1 and T32.32 that is used to specify the tool required.

The format for this number is **T12.12** The 1st 2 digits are for the tool plate position of the tool.

This number indicates the location on the tool plate that the tool is at.

T12.12 The 2nd 2 digits are for the Geometry and wear offset to be applied to the tool selected.

In normal operation the 1st 2 digits are the same as the 2nd 2 digits **T12.12**

Using dissimilar tool offset numbers

These numbers do not have to correspond. On most machines 32 offsets are provided, This allows you to assign the extra offset values to multiple tool offsets.

Example : Give 2 offsets to a groove tool.

T5.5 would be the left corner and **T5.15** would be the right corner. This allows the operator to adjust the width of a groove without changing the program.

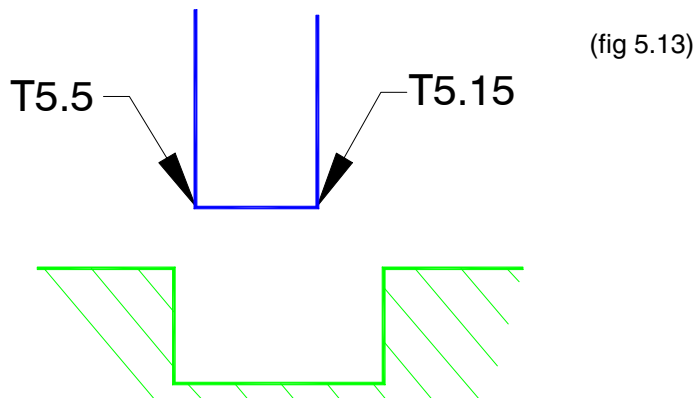

This can be useful if different radii are on each corner of the tool as Toolnose radius compensation can be used for both sides of the groove.

G25 Unconditional Jump

The G25 command is used to jump a single block or a group of blocks.

It is also used to repeat groups of blocks to use in the form of subroutines.

Example #1

N20 G25 N60 the CNC will jump directly to block N60

This could be used to skip blocks that are needed on another similar part with the same program, but do not require a programmed tool.

Example #2

Using the G25 unconditional jump command in a Live tool side drilling operation

The operation involves tool T32 drilling 4 holes in a line along a Z axis.

N80 G25 N1000.1030.4

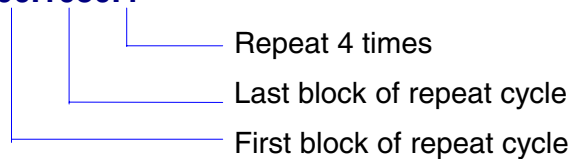

Note: The decimal point must be use as shown in the example when writing a G25 repeat cycle. It is not necessary in a jump command.

Main Program:

%00102

N00 (G25 jump to sub program)

N10 G90 G94 T32.32 M5 M8

N20 G00 X1.1 M20(Live tool on)

N30 Z0

N40 G25 N1000.1030.4

N50 G00 Z2. M21(Live tool off)

N60 M30

N1000 G91 Z-.2 (incremental move to Z-.2 start position)

N1010 G90 G00 X1.01 (Start position for drilling in X)

N1020 G01 X.75 F50 Feed to X.75 at 5" per minute)

N1030 G00 X1.1 (Rapid to safe X position)

Cross drilling
(Fig 5.14)

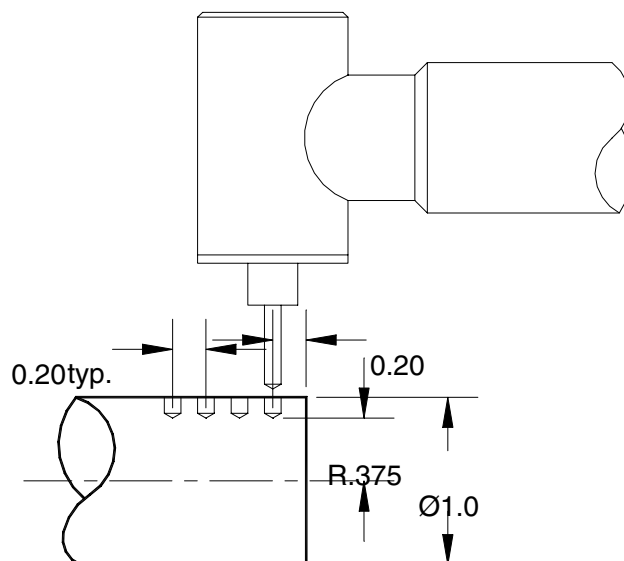

G25 Unconditional Jump

Jumping over unneeded blocks

If a program is written where sections are not needed it is possible to jump over these blocks.

Program format:

```
%00103
N00 (Facing skip using G25)
N10 G90 G95 S1200 T1.1 M3
N20 G0 X1.
N30 Z.1
N40 G25 N60(Skip face cut)
N50 G1 X-.01 F.003(Face cut)
N60 G0 X.9 Z.05
N70 G1 Z-1.
N80 G00 X1.1 Z1.5 M5 M9
N90 M30
```

Looping programs when bar working

The G25 command can be used to loop a program indefinitely or a fixed number of times. The Main program becomes a sub program that is called a fixed number of times.

Program format:

```
%00104
N00 (Cycle count for barfeed)
N10 G25 N30.1200.99
N20 M30
N30 G90 G95 S2500 T1.1 M3 M8
N40 G00 X1.01
N50 Z0.01
N60 -----
N70 -----
N1200 G00 Z1.5 M9
N1210 M30
```

This example would loop the program contained in blocks 30 thru 1200, 99 times(Max number)

Looping more than 99 times

If it is necessary to loop more than 99 times, it is possible to use a macro variable to specify the number required, up to 254 parts. This would also allow a part counter to be set up in the variable table to keep track of parts produced.

Program format:

```
%00105
N00 (Macro variable count for barfeed)
N10 P253=K125(Quantity of parts to run)
N20 P254=K0(set counter to zero)
N30 G25 N50.60.P253
N40 M30
N50 P254 = F13 P254(F13= add 1 to variable)
N60 G4 K.25(Dwell for .5 seconds)
```

Each time you restart the program after the quantity run, the counter resets to zero by line N20 This requires no operator intervention except loading bars.

G36 Automatic Radius Blend

G36 Automatic radius blend

This function automatically blends the corner of 2 blocks with a radius of a programmed amount. The following examples show how this is used.

Lines only

Line to line moves can be in X,Z or both.

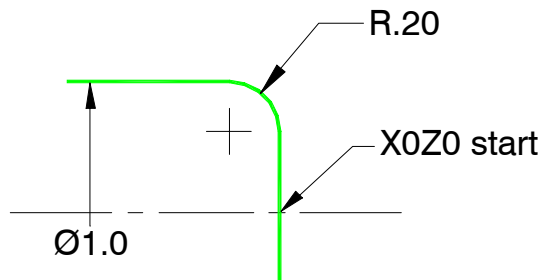

Example 1 line parallel to axis(fig 5.15)

```
%00106
N0 G90 G95 S1200 T1.1 M3
N10 G00 X0
N20 Z0
N30 G01 G36 R.2 X1.0
N40 G01 Z-1.
```

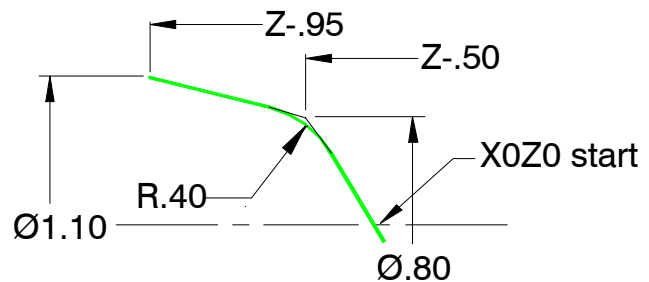

Example 2 lines non-parallel to axis(fig 5.16)

```
%00107
N0 G90 G95 S1200 T1.1 M3
N10 G00 X0
N20 Z0
N30 G01 G36 R.4 X.8 Z-.5
N40 G01 X1.1 Z-.95
```

Arcs and lines, arc to arcs

Line to arc, and arc to arc moves can be in many configurations.

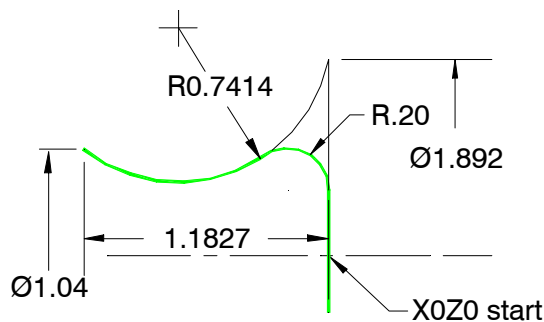

Example 3 line to arc(fig 5.17)

```
%00108
N0 G90 G95 S1200 T1.1 M3
N10 G00 X0
N20 Z0
N30 G01 G36 R.2 X1.892
N40 G02 X1.04 Z-1.1827
```

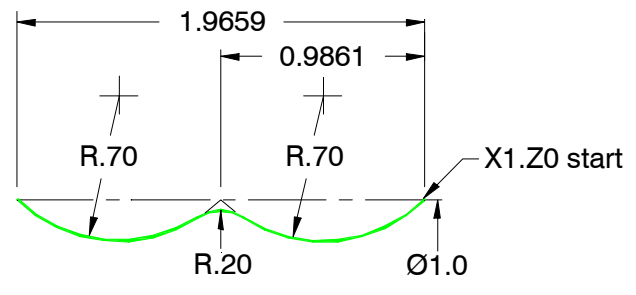

Example 4 arc to arc(fig 5.18)

```
%00109
N0 G90 G95 S1200 T1.1 M3
N10 G00 X1.0
N20 Z0
N30 G02 G36 R.2 X1.0 Z-.9861
N40 G02 X1.0 Z-1.9659
```

G39 Automatic chamfer blend

This feature can be used in a similar manner to G36 except that only lines may be chamfered.

Toolnose Radius Compensation

G40, G41, G42 Compensation codes

These 3 codes define how the machine calculates toolnose radius compensation (TNRC).

G40 Compensation code

G40 cancels the active G41 or G42 mode.

R and F Compensation registers

In the Tool Offset pages there are registers for X and Z, I and K, and R and F.

The R and F registers are critical to the correct function of TNRC.

R is the register for the radius of the tool tip. All commercially available tools have a radius, It may be as small as 0.004" or as large as 0.500". This tool nose radius is the reason for TNRC.

The F register is used to help the control decide how to compensate for the radius. If the control knows how to apply the direction of compensation, the program will produce the correct shape.

Defining F register values

There are 9 values for the F number 0-9. (0 and 9 mean the same value, tool radius center)

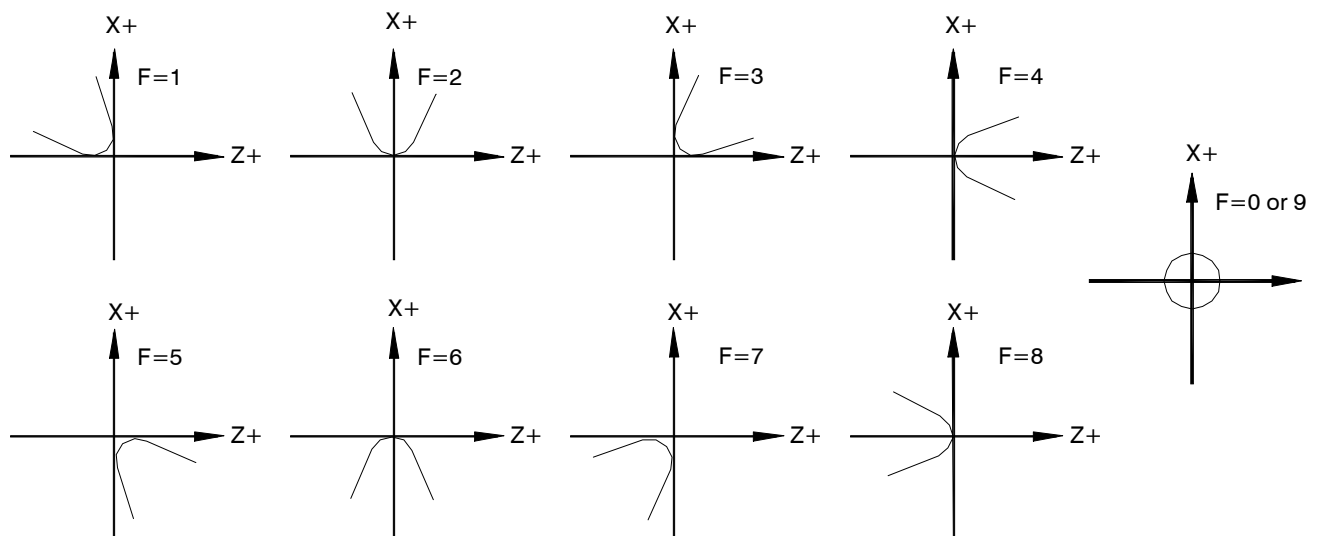

Tool tip codes(fig 5.19)

These codes are defined by the X axis positive direction, If this is reversed the F code values change.

As figure 5.19 shows, the numbers correspond to a position around an XZ reference point.

In general use the tool codes would represent the following tool types.

- F1 would be the right side of a grooving tool or a back turning tool on X+
- F3 would be an outside turning tool on X+ or a boring bar on X-
- F4 would be a drill or facing tool with the center on the middle of the radius
- F5 would be a boring bar on X+ or an outside turning tool on X-
- F0 or F9 are used when programming the tool radius center.

Note:

When threading you would not use TNRC and there for do not need an F code for the tool tip, It is a common mistake to apply an F2 or F6 to a threading tool tip.

Toolnose Radius Compensation

Compensation Directions

When machining a profile to the actual drawing dimensions the control has to calculate the amount of change that is required to compensate for TNRC. It also need to know on which side of the profile it has to compensate.

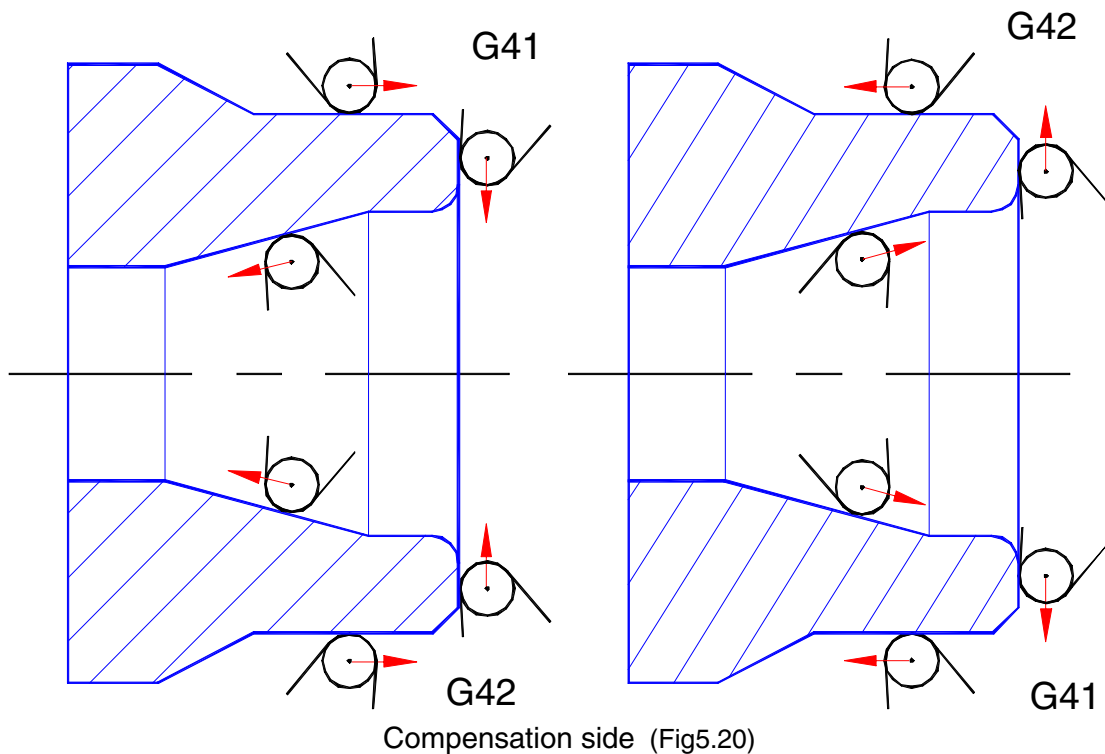

As can be seen in fig 5.20 profiling towards the chuck on the X+ side would require a G42 code with a value of F3, While boring on the X+ side would require a G41 code with a Value of F5.

If a profile was generated on the X- side the G41 would be used for an outside profile but would require a Value of F5, While a boring bar would require a G42 with a value of F3.

Entrance and exit amounts for TNRC

For TNRC to be active the controller requires that the approach distance be at least 2 times the radius value.

For a complete explanation of TNRC please refer to the Fagor 8025 programming manual.

Basic Format for a Program

Start-Up Block

A start-up block is recommended at the beginning of each tool cutting sequence. By programming each tool as a separate program, the tools can be easily adjusted or changed individually without running through the whole program.

A typical start-up block would be as follows:

N10 G90 G95 S2000 T1.1 M3 M8

N10 = Block #
G90 = Absolute coordinates
G95 = Feed in Inches per revolution
S2000 = Spindle RPM
T1.1 = Call up Tool #1
M3 = Spindle Forward
M8 = Coolant On

N	Block number (start with N10)
G	G codes or Prep Functions
C,X,Z,	Axis coordinates in that order
F	Feedrate
S	Spindle Speed
T	Tool Number
M	M Functions

Coordinate moves and feed rates are usually not included in the start-up block.

After the 1st block, the next block normally contains an axis movement.

It is strongly recommended that only an X axis move be programmed, On a Gang tooling lathe the main cause of tool crashes is a Z move after a tool clearance move.

If Constant surface speed is to be programmed the 2nd line normally should be G92 and a maximum spindle speed.

Example: N0 G90 G95 T1.1 M8
N10 G92 S3500
N20 G96 S500 M3
N30 G00 X1.

A prior spindle speed can be programmed to start the spindle and decrease cycle time

Example: N0 G90 G95 S2500 T1.1 M3 M8
N10 G92 S3500
N20 G96 S500
N30 G00 X1.

Basic Format for a Program

Ending a tool sequence

An ending block is recommended at the end of each tool cutting sequence. By programming a safe rapid distance for the next tool so that it can rapid to its start point without an interference, and finally an M01 at the end of the sequence.

Example:

```
N50 G00 Z1.5
```

```
N60 M01
```

Ending a cycle sequence

At the end of a program cycle a different sequence is required. Normally turn the coolant and spindle off prior to the final line.

Example:

```
N50 G00 Z1.5 M09 M05
```

```
N60 M30
```

The controller will some times refuse to accept a block of code when typing in using the editor, This is caused by a format error, either a bad or missing code or a block in the wrong order. If this happens re read the line and see if it does not conform to the outline suggested.

Generating programs

When programming it is possible to create a working program where all the moves are programmed line by line, every machine movement is commanded by either a G00, G01, G02, G03, G04 this is effective but will lead to long programs that require much thought and are difficult to modify.

Canned cycles are a way to simplify programming, by making routines that require a large amount of code and create a cycle using a fixed group of variables to do the same cycle. These are known as canned cycles.

In the Canned cycle section a brief overview of the most used cycles is presented.

These do not present all the cycles available, but provide information on the most used.

Sample programs

In the following pages a sample program explains the main usage of different methods of generating a program, using both long code(No cycles) and canned cycles to simplify programming.

Sample 2 Axis Program

Long coding

This example shows a part generated with long code.

```
%00110
N000 G90 G95 S3000 T1.1 M4 M8(TURNING TOOL)
N010 G00 X.77
N020 G00 Z0
N030 G01 X-.01 F.003
N040 G00 X.52 Z.01
N050 G01 Z-.634 F.006
N060 G00 X.55 Z.010
N070 G00 X.41
N080 G01 Z-.092
N090 G00 X.43 Z.01
N100 G00 X0
N110 G01 Z0 F.003
N120 G01 X.18
N130 G03 X.3 Z-.06 R.06
N140 G01 Z-.095
N150 G01 X.39
N160 G01 Z-.14
N170 G01 X.5 Z-.3119
N180 G01 Z-.636
N190 G01 X.75
N200 G00 Z1.
N210 M01
N220 G90 G95 S1200 T2.2 M3 M8(.125 DRILL)
N230 G00 X0
N240 G00 Z.05
N250 G01 Z-.125 F.003
N260 G00 Z.1
N270 G00 Z-.115
N280 G01 Z-.250
N290 G00 Z.1
N300 G00 Z-.240
N310 G01 Z-.375
N320 G00 Z.1
N330 G00 Z1.
N340 M01
N350 G90 G95 S1000 T3.3 M3 M8(.05 WIDE GROOVE TOOL)
N360 G00 X.625
N370 G00 Z-.533
N380 G00 X.515
N390 G01 X.400 F.0015
N400 G00 X.515
N410 G00 X.75 Z1.0 M05 M09
N420 M30
```

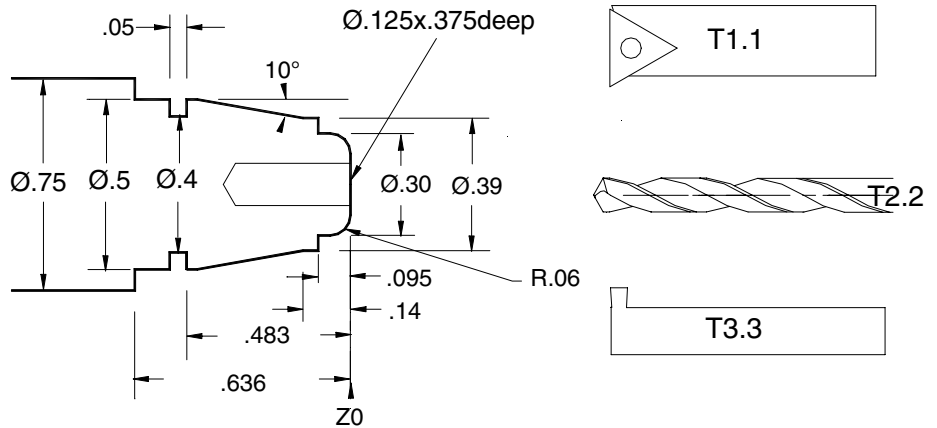

Sample part drawing and tool list (fig 5.21)

Sample 2 Axis Program

Explanation of sample program

```
%00110
N000 G90 G95 S3000 T1.1 M4 Absolute IPR spindle 3000rpm Tool 1 direction counterclockwise
N010 G00 X.77 Rapid feed to X+.77 diameter
N020 G00 Z0 Rapid to face Z0
N030 G01 X-.01 F.003 Facing cut to X-.01 at .003 IPR
N040 G00 X.52 Z.01 Rapid to X+.52 Z+ .01
N050 G01 Z-.634 F.006 Feed to Z-.634 AT .006 IPR
N060 G00 X.55 Z.01 Rapid to X+.55 Z+.01
N070 G00 X.41 Rapid to X+.41
N080 G01 Z-.092 Feed to Z-.092
N090 G00 Z.01 Rapid to Z+.01
N100 G00 X0 Rapid to X0
N110 G01 Z0 F.003 Feed to Z0 AT .003 IPR, beginning of finish pass
N120 G01 X.180 Feed to X.18, start of radius
N130 G03 X.3 Z-.06 R.06 Generate a .06 radius
N140 G01 Z-.095 Feed to Z- .095
N150 G01 X.39 Feed to X+.39
N160 G01 Z-.14 Feed to Z-.14
N170 G01 X.500 Z- .3119 Feed along 10° taper
N180 G01 Z-.636 Feed to Z-.636
N190 G01 X.75 Feed off material to X+.75
N200 G00 Z1. Rapid to Z1., Safe position for next tool
N210 M01 Optional stop
N220 G90 G95 S1200 T2.2 M3 Start-up block for tool #2 .125 Drill 1200 rpm clockwise
N230 G0 X0 Rapid to X0
N240 Z.1 Rapid to Z.1
N250 G01 Z-.125 F.003 Feed to Z-.125 at .003 IPR
N260 G00 Z.1 Rapid out to Z+.1
N270 G00 Z-.115 Rapid into hole +.01 from last position
N280 G01 Z-.250 Feed to Z-.250 at .003 IPR
N290 G00 Z.1 Rapid out to Z+.1
N300 G00 Z-.240 Rapid into hole +.01 from last position
N310 G01 Z-.375 Feed to Z-.375 at .003 IPR
N320 G00 Z.1 Rapid out to Z+.1
N330 G00 Z1. Rapid to Z1., Safe position for next tool
N340 M01 Optional stop
N350 G90 G95 S1000 T3.3 M3 Start-up block for tool #3 Groove tool
N360 G00 X-.625 Rapid to X-.625
N370 G00 Z-.533 Rapid to Z-.533, groove position
N380 G00 X-.515 Rapid to safe position above .5 turned diameter
N390 G01 X-.40 F.0015 Feed to X-.40 at .0015IPR
N400 G00 X-.515 Rapid out of groove to X-.515
N410 G00 X-.75 Z2.0 M05 M09 Rapid to safe Z position turn off spindle and coolant
N420 M30 End of program
```

Sample 2 Axis Program

Canned cycle coding

This example shows canned cycles and shortcut in code

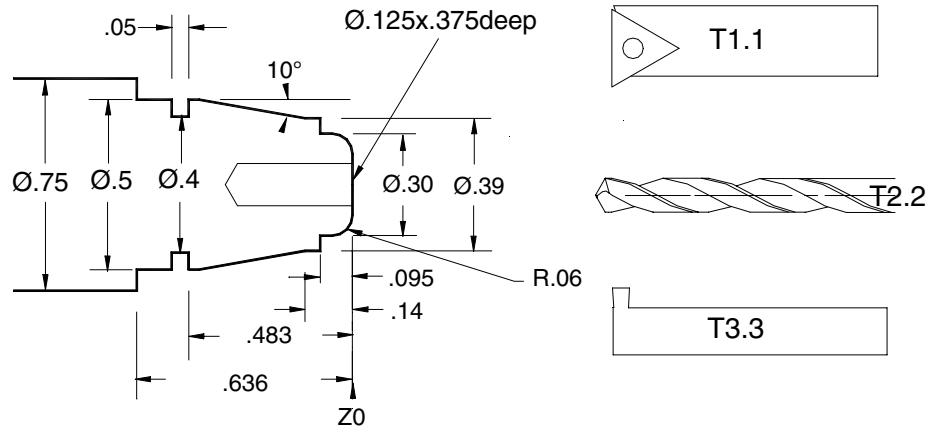

```
%00111
N000 G90 G95 S3000 T1.1 M4 M8(TURNING TOOL)
N010 G0 X.77
N020 Z0
N030 G1 X-.01 F.003
N040 G0 X.76 Z.01
N050 G68 P0=K0 P1=K0 P5=K.06 P7=K.010 P8=K.002 P9=K.003 P13=K400 P14=K470
N060 G0 Z1.
N070 M1
N080 G90 G95 S1200 T2.2 M3 M8(.125 DRILL)
N090 G0 X0
N100 Z.1
N110 G1 Z.05 F.003
N120 G83 P0=K0 P1=K0 P4=K.375 P5=K.125 P6=K.010 P15=K0 P16=K0 P17=K.01
N130 G0 Z1.
N140 M1
N115 G90 G95 S1000 T3.3 M3 M8(.05 WIDE GROOVE TOOL)
N160 G0 X.625
N170 Z-.533
N180 X.515
N190 G1 X.4 F.0015
N200 X.515
N210 G0 X.6 Z1. M5 M9
N220 M30
N400 G1 X.18 Z0
N410 G03 X.3 Z-.06 I0 K-.06(Profile definition)
N420 G01 X.3 Z-.095
N430 X.39 Z-.095
N440 X.39 Z-.140
N450 X.50 Z-.3119
N460 X.50 Z-.636
N470 X.75 Z-.636
```

Explanation of sample program

As can be seen 12 blocks of code were removed from the program, as well as repetitive G codes, refer to the canned cycles section for explanations of the 2 cycles used.

Sample Barfeed Program

Variables related to Bar feeding

There are three variables related to barfeeding:

- Part Length
- Cutoff tool width
- Amount of material left out of collet

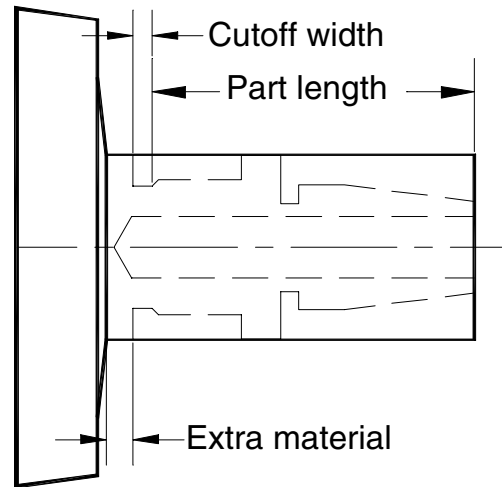

Auto Barfeeding with a Bar Pusher

Using a barstop, and assuming Z0 for the end of the part and no barfeed interface for magazine loading. The program would be formatted like this:

```
%00112
N0 G90 G94 T32.32 M5   Absolute, Inch/min, T32 offset and spindle stop
N10 G0 X0              Rapid to X0
N20 Z-??              Rapid to Part length
N30 M10               Open collet
N40 G4 K.75           Dwell for ¾ seconds
N50 G1 Z.015 F800     Feed bar out against stop at 80 IPM
N60 M11               Close collet
N70 G4 K.75           Dwell for ¾ seconds
N80 G0 Z1.            Rapid out to a safe Z position
N90 M1                Optional stop
```

Bar pulling with a Bar Puller

A bar puller requires an extra variable:

- Amount of material to be gripped

Using a bar puller, and assuming Z0 for the end of the part. The program would be formatted like this:

```
%00113
N0 G90 G94 T32.32 M5   Absolute, Inch/min, T32 offset and spindle stop
N10 G00 X??           Rapid to X size allowing clearance for fingers over stock
N20 Z.1               Rapid to safe Z point
N30 G01 Z-??         Feed to Z-(part length + grip distance)
N40 X0                Feed to X0 to grip bar
N50 M10               Open collet
N60 G04 K.75          Dwell for ¾ seconds
N70 G01 Z.015 F800     Feed bar out against stop at 80 IPM
N80 M11               Close collet
N90 G04 K.75          Dwell for ¾ seconds
N100 G00 X??         Rapid out to safe X position
N110 G0 Z1.           Rapid out to a safe Z position
N120 M1               Optional stop
```

Section 6

Fagor 8025TG

Canned cycle programming

Canned Cycles

Most commonly used canned cycles

These are the commonly used canned cycles. please refer to the Fagor programming manual for a full list of cycles.

- G68** Roughing in Z axis
- G83** Hole drilling canned cycle
- G86** Threading canned cycle

Note When entering a block containing a canned cycle a short cut is provided after entering the Gxx value. press soft key “help” then enter the values at the proper “P” numbers.

Always precede a canned cycle with a feed rate.

All canned cycles use a similar format, and each P code is common through out the cycles.

For example:

- P0** The X location of point A in absolute
- P1** The Z location of point A in absolute
- P2** The X location of point B in absolute for G81 G82 G84 G85
- P3** The Z location of point B in absolute for G81 G82 G84 G85
- P4** The depth of thread or stock to be removed
- P5** The depth of cut or depth of pass or groove tool width
- P6** The safety distance
- P7** The finishing stock allowance in X
- P8** The finishing stock allowance in Z
- P9** The finish pass feedrate
- P10** The Thread pitch along X or Z
- P11** The Thread exit
- P12** The angle of the tool nose in threading
- P13** The block number to define a profile start
- P14** The block number to define a profile end
- P15** The dwell amount
- P16** The rapid amount
- P17** The safety distance between pecks in drilling
- P18** The I distance for G84 and G85
- P19** The K distance for G84 and G85

G68 Roughing In Z Axis

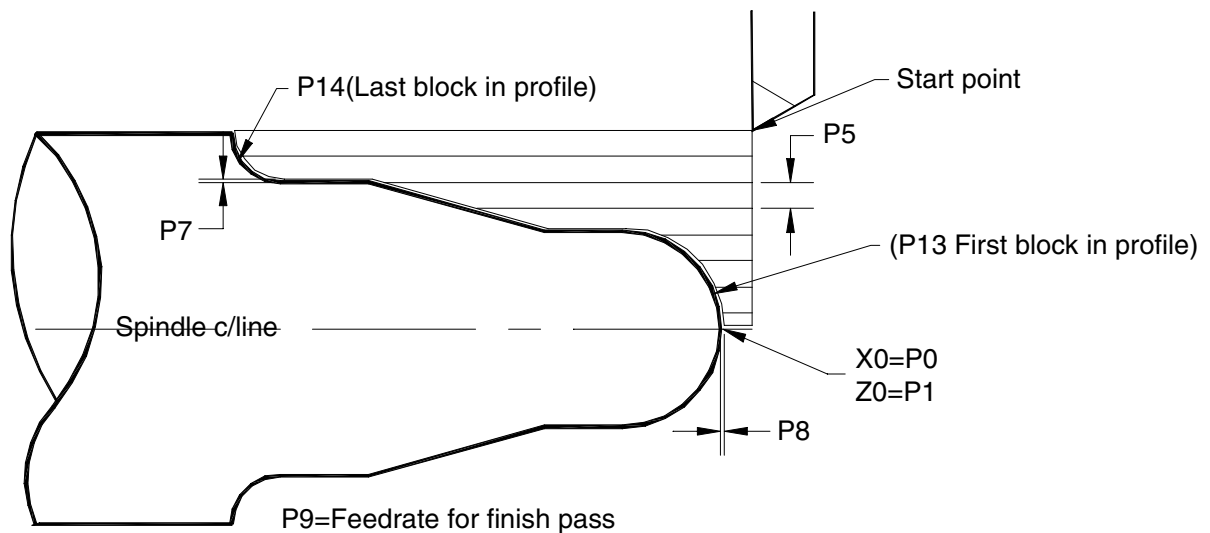

Parameters for G68(fig 6.1)

Format:

N4 G86 P0=K□ P1=K□ P5=K□ P7=K□ P8=K□ P9=K□ P13=K□ P14=K□

Meaning of parameters:

- P0 The start point of the final pass in X
- P1 The start point of the final path in Z
- P5 The stock removed per pass
- P7 The stock left on the X dia's for finishing (in radius)
- P8 The stock left on the Z faces for finishing
- P9 The feedrate of the finishing pass (if zero is entered no finish will occur)
- P13 The first block of the final path. P0 and P1 will put the tool in position to begin in the first block.
- P14 The last block of the final path. the tool will automatically return to the start point when the cycle is complete.

Notes:

1. The profile can only use lines or arcs
2. Both X and Z locations must be programmed on each line.
3. Include arc centers (I and K) when using G2 or G3
4. Always position the tool outside the material (start point) before calling G68.
5. Do not program back tapers or error #4 will result.
6. when using G41 or G42 the value of P5 (roughing pass) must be 2.1 times the tool nose radius.
(in example above if tool has .03 radius then P5 must be at least .062 or error #31 will result)
7. See Fagor programming manual for explanations of P9 and P10

G68 Roughing Cycle Example

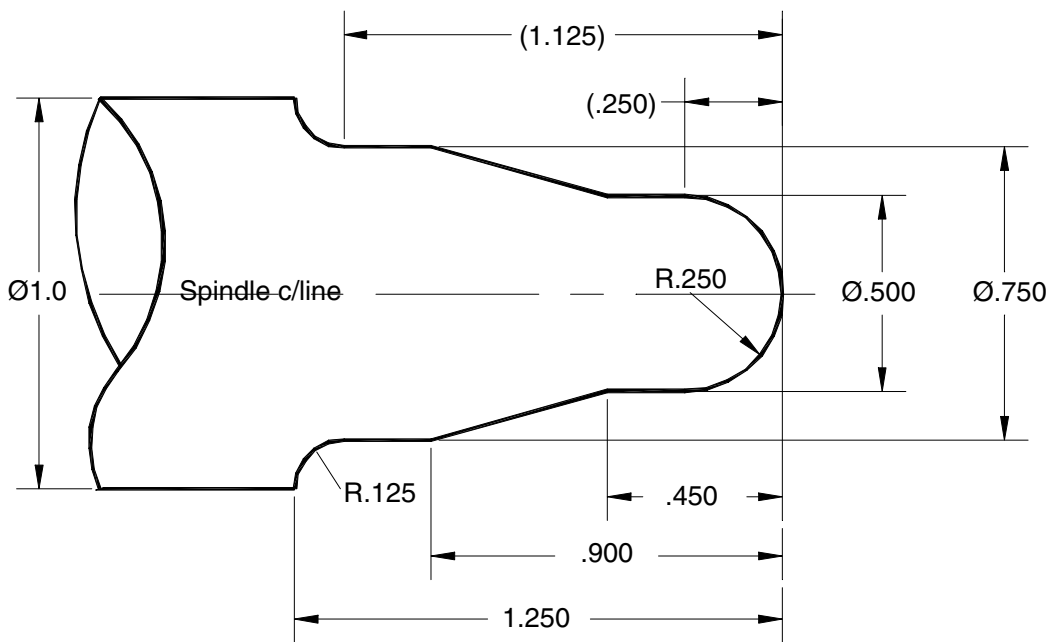

Sample profile(fig 6.2)

Sample program

```

%00114
N00 G90 G95 S1000 T1.1 M3 M8
N10 G42 G0 X1.1 Z.1
N20 G1 F.004(Feed Rate For Roughing)
N30 G68 P0=K0 P1=K0 P5=K.062 P7=K.010 P8=K.002 P9=K.002 P13=K200 P14=K250
N40 G40 G0 Z1.0 (Clear Tool And Exit Tool Nose Radius Comp)
N50 X1.5 M5
N60 M30
N200 G3 X.500 Z-.250 I0 K-.250 Treat this final path as a subroutine.
N210 G1 X.500 Z-.450
N220 X.750 Z-.900
N230 X.750 Z-1.125
N240 G2 X1.00 Z-1.25 I.125 K0
N250 G1 X1.05 Z-1.25
    
```

The parameters for the G68 cycle are:

P0=K0	X0 start point of profile
P1=K0	Z0 start point of profile
P5=K.062	0.062 depth of cut (Radius value)
P7=K.010	0.010 stock on X diameters(Radius value)
P8=K.002	0.002 stock on Z lengths
P9=K.002	Finish feedrate for final pass
P13=K200	N200 block start profile description
P14=K250	N250 block end profile description

Line N10 rapids to the start position (Outside the rough stock)

Line N20 sets the feedrate for roughing

G83 Deep Hole Drilling

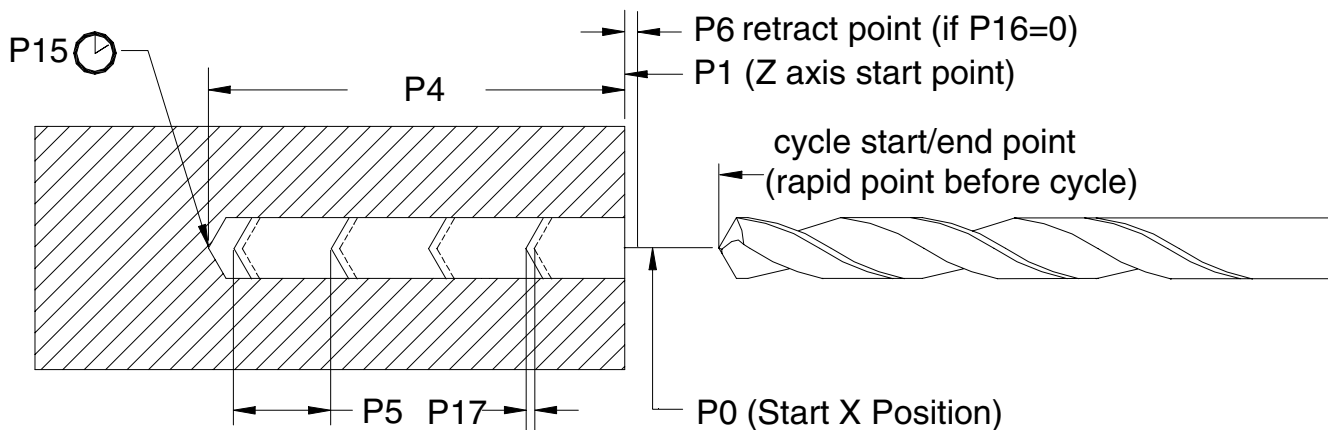

Hole Drilling Cycle(Fig 6.3)

Format:

N4 G83 P0=K□ P1=K□ P4=K□ P5=K□ P6=K□ P15=K□ P16=K□ P17=K□

Meaning of parameters:

- P0** Absolute X value of the point where the drilling or circular groove is desired (if different from zero) in radius or diameters
- P1** Absolute Z value of the point where the drilling is to rapid to.
- P4** Total depth of the hole. It will have positive value when drilled towards the negative direction of the Z axis and vice versa. If it is zero, error code 3 will be displayed.
- P5** Max. peck size. The CNC will execute the minimum number of equal passes, smaller than P5 until the total depth, defined by P4, is reached.
If it is equal to or smaller than zero, error code 3 will be displayed.
- P6** Safety distance. It defines the distance to the part from the point where the tool ends the positioning approach. If it is negative, error code 3 will be generated.
- P15** Dwell. It identifies the value in seconds of the dwell at the bottom of the hole.
If it is negative, error code 3 will be displayed.
- P16** It indicates the incremental value of the G00 movement after each pass. If it is zero, this movement will be executed up to the start of drilling point.
If it has a value the tool will rapid out of the hole by the amount given.
If it is negative, error 3 will be displayed.
- P17** It indicates the safety distance between the bottom of the previous penetration and the point where the tool ends the rapid approach for a subsequent penetration.
If it is negative, error code 3 will be displayed.

The machining conditions (feedrate, spindle rotation, etc.) must be programmed before calling the cycle. The parameters can be programmed in the calling block or in previous blocks.

- The cycle does not alter the calling parameters and thus they can be used for future cycles.
- The parameters P90 to P96 are altered. The exit conditions are G00, G07, G40 and G90.
- The cycle starts with a G00 approach to point P1 and ends at P1 as well.

G83 Constant Depth Peck Drilling Cycle

G83 peck drilling with full retract

In this sample program, ZO(zero) is the face of the part and the final depth of the hole is 1.0 inches.

G83 Auto Drilling Sample Program

```
%00115  
N05 (Peck drill example)  
N10 G90 G95 S1200 T12.12 M3 M8  
N20 G00 X0  
N30 Z.1 F.003  
N40 G83 P0=K0 P1=K0 P4=K1. P5=K0.2 P6=K0.05 P15=K0.5 P16=K0 P17=K0.01  
N50 G0 Z1. M9 M5  
N60 M30
```

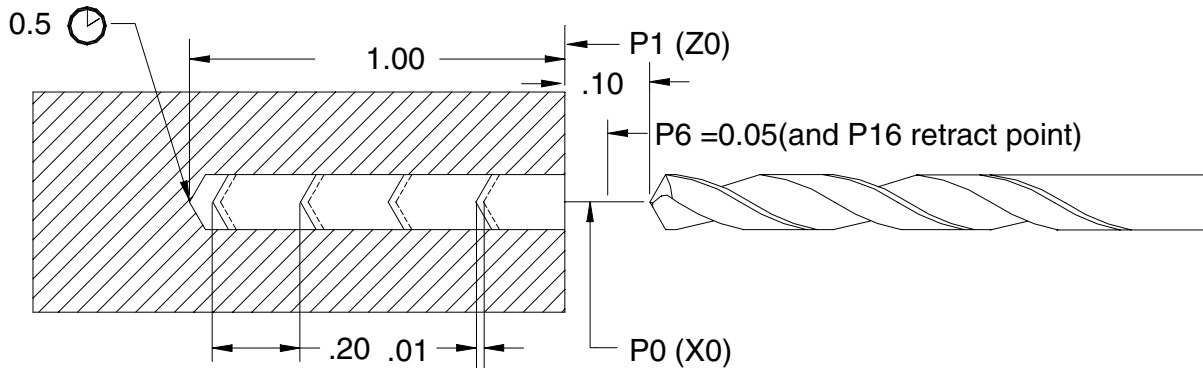

G83 Auto Drilling Cycle (Fig 6.4)

G83 peck drilling with controlled retract

In this sample program, ZO(zero) is the face of the part and the final depth of the hole is 1.0 inches.

```
%00116  
N05 (Peck drill example)  
N10 G90 G95 S1200 T12.12 M3 M8  
N20 G00 X0  
N30 Z.1 F.003  
N40 G83 P0=K0 P1=K0 P4=K1. P5=K0.2 P6=K0.05 P15=K0.5 P16=K0.1 P17=K0.01  
N50 G0 Z1. M9 M5  
N60 M30
```

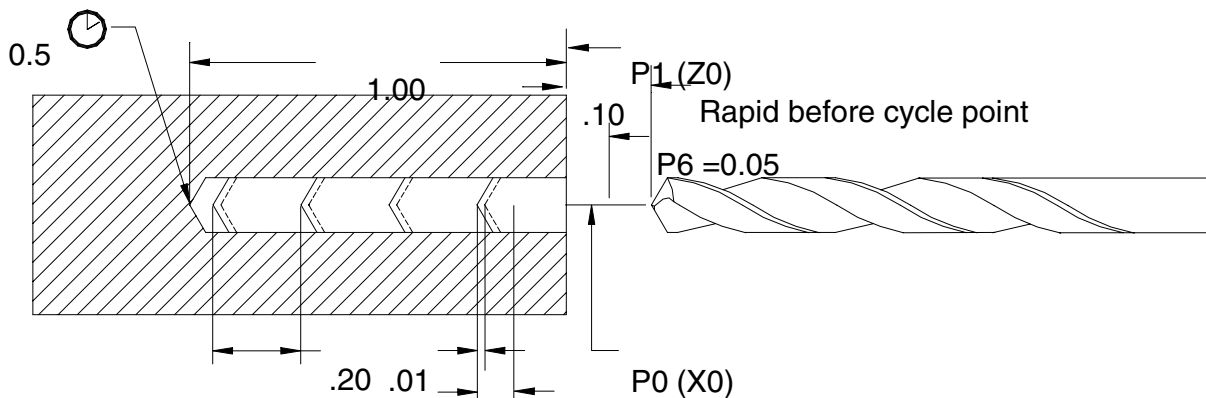

G83 drilling Cycle fixed retract (Fig 6.5)

P16 has been changed to 0.1 this forces the control to retract the drill 0.1 out of the hole and then back to the last depth less the P17 value 0.01.

G86 Threading Cycle

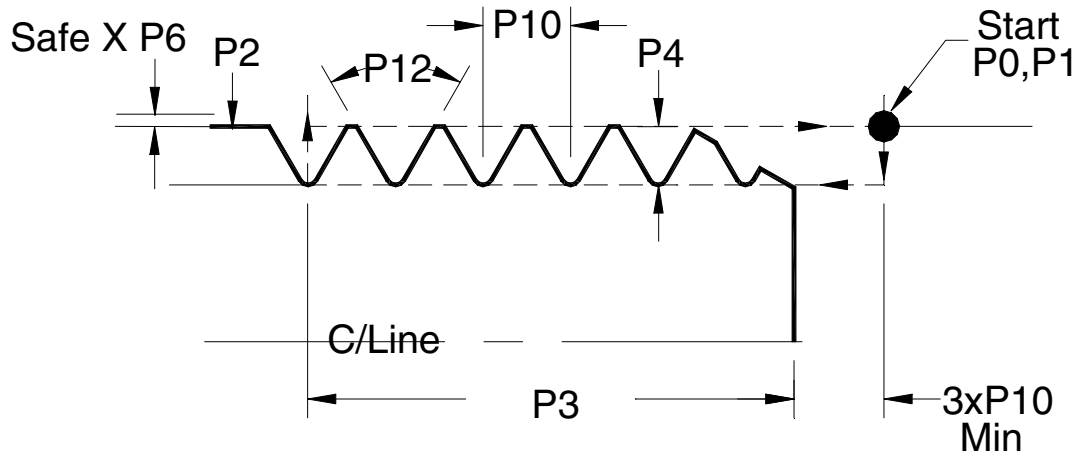

G86 Cycle Format(fig 6.6)

Parameter definitions

- P0** Major diameter at start of thread
- P1** Start point in Z axis
- P2** Major diameter at end of thread (See note 1)
- P3** Absolute position at end of thread (See note 2)
- P4** Total depth of thread per side (See note 3)
- P5** Depth of first pass and factor for remaining passes.(See note 4)
- P6** Safety distance for X axis retract at end point of thread
- P7** Final pass as a radius value.(See note 5)
- P10** Thread lead (Pitch)
- P11** Exit length
- P12** Included angle of threading tool.(See note 6)

Notes:

1. For straight threads use same value as P0. For taper threads use different value in P2
2. Include sign for Z minus (absolute position)
3. For external threads this will be a positive number. For internal threads it will be negative.
(If the X value is negative reverse note 3)
4. If the sign is positive the control will calculate the remaining depths of cut.
If the sign is negative the control uses this value for all cuts.
If the value is zero error #3 will be issued.
5. If the value is zero the previous pass is repeated.
If the value is positive the pass will be infed at $P12/2$
If the value is negative the infeed will be a plunge pass taking equal amounts off each flank.
6. This value allows you to either infed at an angle, or plunge into the thread taking equal amounts of both sides.(See compound infed threading)
7. Spindle speed must be programmed prior to the cycle.
8. The feedrate cannot be adjusted by the feedrate override knob during threading.

G86 Threading Cycle

Thread a 1/2" x 13UNC thread 1" long

```
%00117
N00 (1/2x13UN thread)
N10 G90 G95 S1000 T1.1 M3 M8
N20 G00 X-.500 Z.200
N30 G86 P0 = K-.500      (Major diameter at start of thread)
      P1 = K.200        (Start point Z)
      P2 = K-.500      (Major diameter at end of thread)
      P3 = K-1.00      (Length of thread)
      P4 = K-.0471     (Total depth of thread per side)
      P5 = K-.010      (Depth of first pass and factor for remaining passes.)
      P6 = K.020       (Safety distance at start of thread)
      P7 = K.0005      (Final pass)
      P10= K.07692     (Thread lead)
      P11= K.154      (Exit length)
      P12= K60         (Included angle of threading tool)
N40 G00 Z2.0 M09 M05
N50 M30
```

Notes:

A minor diameter is not programmed for the Fagor control. The final pass location is calculated from the start position in P0 and the Value of P4

Minor diameter = $P0 - (P4 * 2)$

The rapid location in block N10 is normally the major diameter.

If you are threading on the minus X(X-) side of the spindle the P4 value has to be - to ensure that you move in the correct direction.

Internal threading

The most common problem encountered with internal threading is the starting position programmed.

Example of a 1/2"x13UN internal thread

```
%00118
N00 (1/2x13UN internal thread)
N10 G90 G95 S1000 T1.1 M3 M8
N20 G00 X-.416 Z.200
N30 G86 P0 = K-.416     (Minor diameter at start of thread)
      P1 = K.200        (Start point Z)
      P2 = K-.416     (Minor diameter at end of thread)
      P3 = K-1.00      (Length of thread)
      P4 = K-.0416     (Total depth of thread per side)
      P5 = K-.010      (Depth of first pass and factor for remaining passes.)
      P6 = K.020       (Safety distance at start of thread)
      P7 = K.0005      (Final pass)
      P10= K.07692     (Thread lead)
      P11= K.154      (Exit length)
      P12= K60         (Included angle of threading tool)
N40 G00 Z2.0 M05 M09
N50 M30
```

Section 7

General Threading information

Threading

General Information

This section is provided to help explain some of the questions when producing threads, The charts and tables are provided for reference only and *Upgrade Technologies* is not responsible for errors.

Maximum feedrate related to spindle speed

The feedrate for precision threading should be lead limited to 200 inches [5080 mm] per minute. Above this value, to the maximum machine feedrate of 600 inches per minute, the lead error should be checked to make certain it does not exceed specification for the individual thread being produced. It is the programmer's responsibility to ensure that the combination of lead and spindle speed does not exceed a feedrate which produces threads that are not within specifications.

The following chart shows the maximum lead in inches that can be cut with a given spindle speed without exceeding the maximum recommended feedrate of 200 IPM [5080 MMPM]. The values are derived from the formulas:

$$\text{LEAD (IPR)} = \frac{200 \text{ IPM}}{\text{RPM}}$$

$$\text{LEAD (MMPR)} = \frac{5080 \text{ MMPM}}{\text{RPM}}$$

Spindle RPM	Maximum programmable Lead	
	Inches per Rev. (Threads per inch)	Millimeters per Rev.
50	2.0000 (0.25)	101.6
100	1.0000 (0.5)	50.80
150	0.6666 (.75)	33.86
200	0.5000 (1.0)	25.40
250	0.4000 (1.25)	20.32
300	0.3333 (1.5)	16.93
500	0.2000 (2.5)	10.16
750	0.1333 (3.75)	6.77
1000	0.1000 (5)	5.08
1500	0.0666 (7.5)	3.38
2000	0.0500 (10)	2.54
2500	0.0400 (12.5)	2.03
3000	0.0333 (15)	1.69
3500	0.0285 (17.5)	1.45
4000	0.0500 (20)	1.27
4500	0.0444 (22.5)	1.12

Thread depths for UN & UNJ Threads

This chart is provided to help speed up programming and give a reference to new programmers.

The values in thread depths can be used for parameter P4 in the G68 canned cycle.

The values in the Pitch column can be used for parameter P10 in single start threads.

Threads per inch	Pitch (Feedrate)	UN Threads		UNJ Threads	
		External Thread depths	Internal thread depths	External Thread depths	internal thread depths
4	0.250000	0.1578	0.1353		
5	0.200000	0.1262	0.1082		
6	0.166666	0.1052	0.0902		
7	0.142857	0.0902	0.0773		
8	0.125000	0.0789	0.0676		
9	0.111111	0.0701	0.0601		
10	0.100000	0.0631	0.0541		
11	0.090909	0.0574	0.0492		
12	0.083333	0.0526	0.0451	0.0504	0.0363
13	0.076923	0.0485	0.0416		
14	0.071428	0.0451	0.0386	0.0432	0.0311
16	0.062500	0.0394	0.0338	0.0378	0.0272
18	0.055555	0.0350	0.0300	0.0336	0.0242
20	0.050000	0.0315	0.0270	0.0303	0.0218
24	0.041666	0.0263	0.0225	0.0252	0.0181
28	0.035714	0.0225	0.0193	0.0216	0.0155
32	0.031250	0.0197	0.0169	0.0189	0.0136
36	0.027777	0.0175	0.0150	0.0168	0.0121
40	0.025000	0.0157	0.0135	0.0151	0.0109
44	0.022727	0.0143	0.0123	0.0137	0.0100
48	0.020833	0.0131	0.0112	0.0126	0.0090

Notes:

- For the bore of an internal thread, program the major diameter less 2 x the P value
- The feedrate for a thread is determined by dividing 1 by the pitch
- Internal UNJ threads have a larger minor diameter.

UN & UNJ External root radii values

This chart is provided to point out the differences between UN and UNJ minor root radii.

TPI	Pitch (Feedrate)	UN External Threads		UNJ External threads	
		Min. Root Flat	Max. Root Radius	Min. Root Radius	Max. Root Radius
80	0.0125	0.0016	0.0018	0.0019	0.0023
72	0.0139	0.0017	0.0020	0.0021	0.0025
64	0.0156	0.0020	0.0023	0.0023	0.0028
56	0.0178	0.0022	0.0026	0.0027	0.0032
48	0.0208	0.0026	0.0030	0.0031	0.0038
44	0.0227	0.0028	0.0033	0.0034	0.0041
40	0.0250	0.0031	0.0036	0.0038	0.0045
36	0.0278	0.0035	0.0040	0.0042	0.0050
32	0.0312	0.0039	0.0045	0.0047	0.0056
28	0.0357	0.0045	0.0052	0.0054	0.0064
24	0.0416	0.0052	0.0060	0.0063	0.0075
20	0.0500	0.0063	0.0072	0.0075	0.0090
18	0.0556	0.0069	0.0080	0.0083	0.0100
16	0.0625	0.0078	0.0090	0.0094	0.0113
14	0.0714	0.0089	0.0103	0.0107	0.0129
13	0.0769	0.0096	0.0111	0.0115	0.0139
12	0.0833	0.0104	0.0120	0.0125	0.0150
11	0.0909	0.0114	0.0131	0.0136	0.0164
10	0.1000	0.0125	0.0144	0.0150	0.0180
9	0.1111	0.0139	0.0160	0.0167	0.0200
8	0.1250	0.0156	0.0180	0.0188	0.0226

Notes:

- These values are useful in determining the correct feedrate and insert shape for the threading of these threads.
- Most insert manufacturers make inserts for these threads, and it is recommended that the correct insert for each thread is used.
- Full profile inserts provide the correct radii and top profile for a given UNJ thread.
- Refer to MIL-S-8879A for a full specification on this critical threading application.

Threadcutting

How the machine can repeat a thread

All lathes feature an accurate encoder that is geared to the spindle through a timing belt. The encoder monitors RPM during a threading pass and when feeding in Inches/mm per Revolution (G95) The encoder sends data controlling X&Z Axis velocity, as determined by the X and Z distance commands, to the control system.

With the Single Block Threadcutting feature, the programmer can cut a thread in any desired number of passes using the G33 preparatory command.

- The G33 command controls single direction per block moves. These moves can be straight or tapered. Another block is programmed to retract the tool tip out of the cut and another block to return it to its start position.
- G33 blocks programmed consecutively can be used to change thread direction.(fig 7.1). (use G05 for continuous block processing)

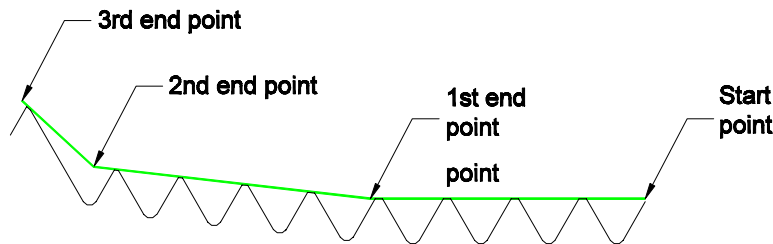

(Fig 7.1)

Pitch and Lead

Thread pitch is the axial distance from the center of one thread to the center of the next. Lead is the distance the screw will advance when turned one revolution. On a single thread screw, the pitch and lead are equal since a screw will advance an amount equal to the pitch when turned one revolution. On a double thread the screw will advance two threads or twice the pitch in one revolution. Therefore, the programmed lead is twice the pitch.

Program the spindle speed for a threading operation in a block of data preceding the threadcutting calling block (G33). This will allow time for the spindle speed to stabilize before entering the threadcutting mode.

The % Feedrate Override switch is not active during a G33 G68 threadcutting pass unless it is set to 0%. When the % Feedrate Override switch is set to 0%, axis motion WILL STOP at the end of the single cycle.

The Spindle INCREASE and DECREASE knob is active.

FEED HOLD is not active during the threadcutting pass, but is active on the return pass.

Establishing a Start Point for Threading

Acceleration and deceleration of machine axis

For accurate thread leads it is essential that the per revolution feedrate of the tool is held constant during the threading pass. The location of the start point for each threading pass is important in that sufficient distance must be provided to accelerate the tool from its Z axis velocity at the end of the infeed to the proper threading velocity.

Due to the nature of the servo-controlled axis drive system, provide a minimum of three pitches or .250 inch, whichever distance is greater, between the first thread to be cut and the start point for the threading pass. (This amount can be cut to 1.5 pitches if a slower RPM is used).

The X axis start point should be equal to the diameter of the workpiece plus an amount of clearance for cycle retract, normally .02"-.04"

Compound infeed and acceleration

This minimum clearance must be provided for all threading passes. If a compound infeed is used, (See "Compound Infeed Threading") work backwards to calculate the start point for the cycle. Beginning with the last threading pass, calculate the Z axis motion during infeed for the first pass. Add this distance to the Z axis clearance (three leads or .250 inch whichever is greater). This gives the Z axis position of the start point for the cycle relative to the first thread to be cut.

Multi-start threads

When threading multi start threads the canned cycle start point sets the location for the other passes. Each new "start" must move away from the original position by the pitch amount.

Plunge and compound infeed

When machining a material that presents threading difficulties due to its toughness or when cutting a coarse thread of extreme depth, it is often desirable to infeed the tool so that the leading edge of the tool cuts the major portion of the material. This reduces deformation of the tool nose due to pressure and heat, thus adding to the tool life. To accomplish this the Z axis position of the tool at the start point of each pass is altered by infeeding both the X and Z axes to produce the desired infeed angle.

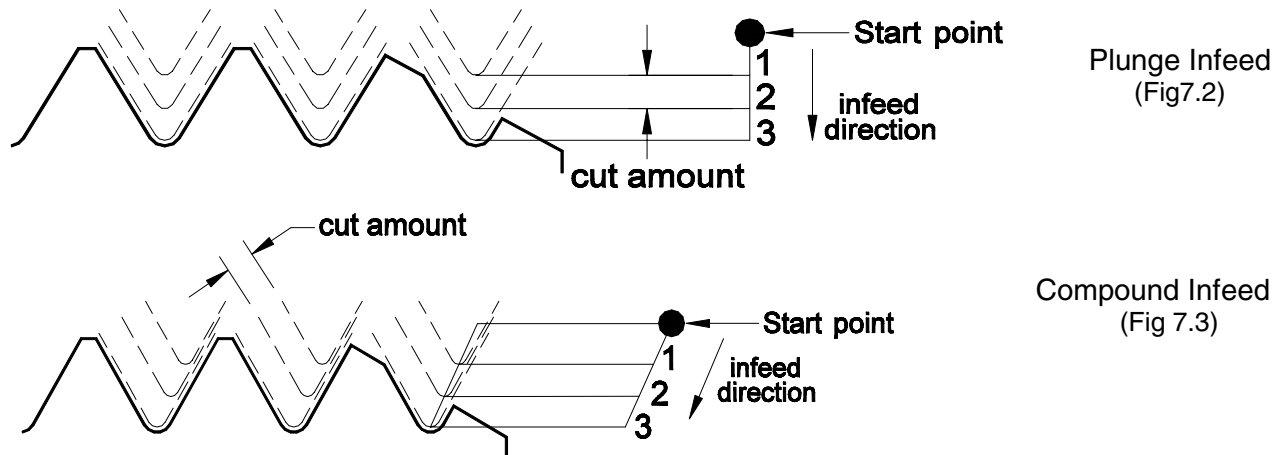

During a compound infeed, (fig 7.3), the tool moves along the X and Z axes from the start point of the threading cycle to the start point for the current threading pass. The infeed can be any angle relative to the face of the part up to 1/2 the included angle of the thread. Axis travel during infeed is as follows: Let X equal the distance traveled along the X axis during infeed. The corresponding distance traveled along the Z axis is equal to the TAN X of the required angle in degrees.

Pipe Threads

Overview of pipe thread sizes

The sample programs in this section are derived from MS33677 for hexagon bar stock

Material is assumed to be steel.

All ANPT pipe threads are the same taper (1.78°) and this is the basic recalculation in these programs.

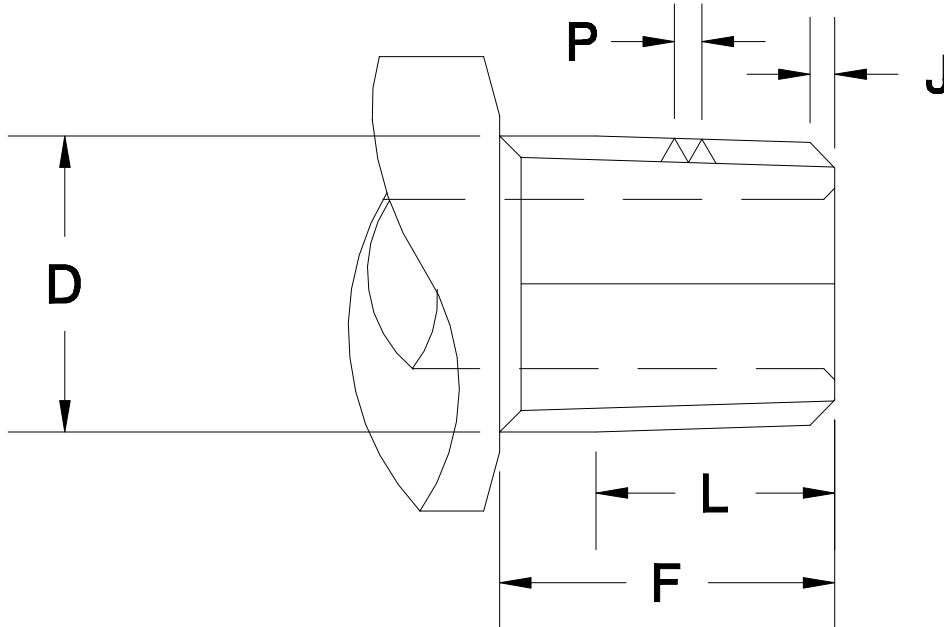

Pipe thread variables(Fig 7.4)

Pipe Size	Thread Size	D Min Dia	F +/- .015	J +/- .016	L Effective length	P Pitch
1/16	1/16 x 27	.312	.391	.031	.2611	.037037
1/8	1/8 x 27	.405	.391	.031	.2639	.037037
1/4	1/4 x 18	.540	.594	.047	.4018	.055555
3/8	3/8 x 18	.675	.609	.047	.4078	.055555
1/2	1/2 x 14	.840	.781	.062	.5337	.071428
3/4	3/4 x 14	1.050	.797	.062	.5457	.071428
1	1.00 x 11-1/2	1.315	.984	.078	.6828	.086956
1-1/4	1.25 x 11-1/2	1.660	1.016	.078	.7068	.086956
1-1/2	1.50 x 11-1/2	1.900	1.031	.078	.7235	.086956
2	2.00 x 11-1/2	2.375	1.062	.078	.7565	.086956
2-1/2	2.50 x 8	2.875	1.562	.109	1.1375	.125000
3	3.00 x 8	3.500	1.625	.109	1.2000	.125000

MS33677 Pipe Chart provided for reference only

Left and Right Hand Threads

Tool hand and direction factors when threading

Gang tool lathes allow you to work on both sides of the spindle, this feature has to be considered when producing threads. The following examples show the variations for different choices.

Internal and External threads

See the figure below to explain these choices.

Right hand threads

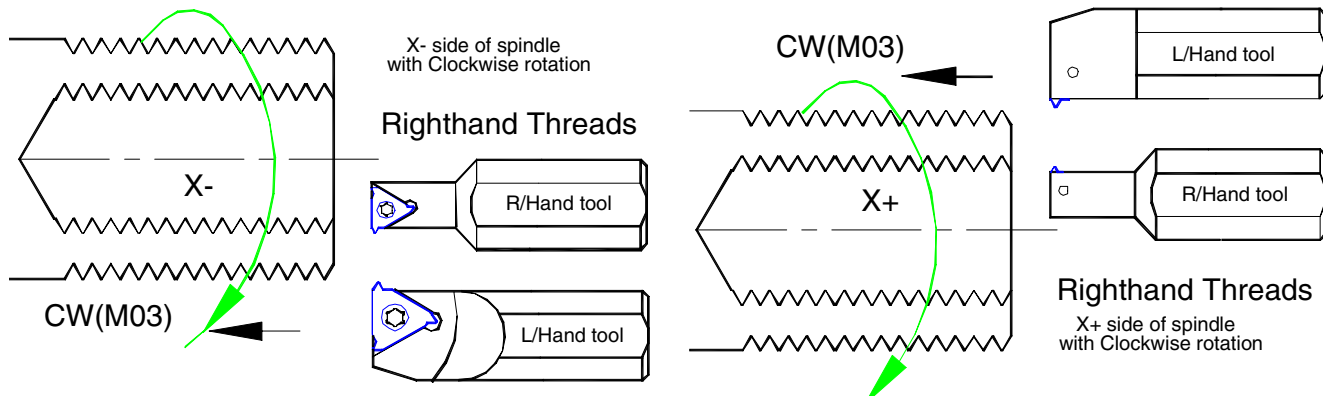

Right hand thread cutting(fig 6.26)

Left hand threads

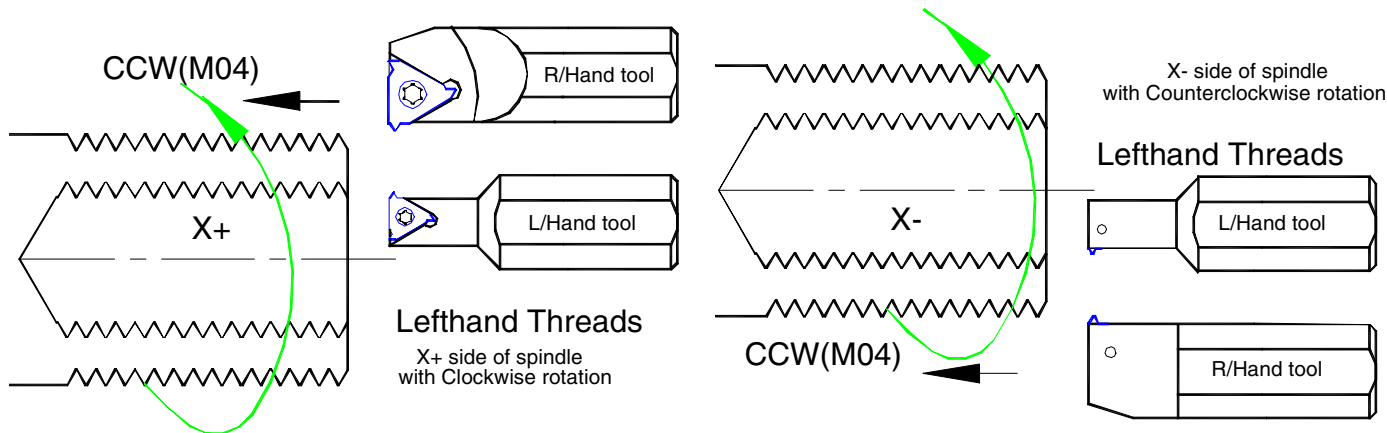

Right hand thread cutting(fig 6.27)

Section 8

Fagor 8025TG Operation

Power Up Procedure

Turn on the main power

1. Verify the emergency stop button is off (out)
2. Press “**OP MODE**” key.
3. Press “**5**” to go to jog mode, to home the machine
4. Press “**Z**” “**F1**” (Zero) “**Cycle Start**”
5. Press “**X**” “**F1**” (Zero) “**Cycle Start**”
6. Turn the feedrate override switch to 10% (for safety purposes this should be done with a new program or if you are unsure of the moves the machine will make).
7. Press “**OP MODE**” and then “**0**” this will put you in automatic mode.

Note! always make sure the program is at the correct block # before pressing the start key.

Press “**N**” “**0**” “**Recall**” if necessary to get the program to N00

8. If the program appears to be running correctly, move the feedrate override switch to 100%.

“**Start**” (the green key) will restart the program

“**Feed hold**” (the red key) will freeze the slides in position.

“**Reset**” (the center key) when pressed twice will stop the program.

You must recall N00 when you reset the program.

Changing the program to be run

To change the program to be run press this key sequence:(We will assume a program # of 00111)

P 111 RECALL

At the top of the screen you will see a **P******* this will change to the program # that you recalled.

If the program you recall is blank the head of the program code displays **N***

Please re-select the correct program if this happens.

Automatic Tool Setting

Before you set tools

Always ensure that the X & Z axes have been homed prior to setting tools.

The following example will automatically set the X and Z tool coordinate for a standard right hand turning tool.

Setting a tool

You should have all tools set on the tool plate prior to tool setting. Decide which numbers are to be assigned to each tool.

In this example it is assumed that T1 is to be set. Check that the jog knob is set to feedrate override mode.

Press this sequence of buttons to set a tool at **T1**

“OP MODE”

“5”

“T1.1”

“Cycle Start”

The screen will now display **T01**

Starting the spindle before cutting

In Jog mode press

“S1200 M4”

“Cycle Start”

This will start the spindle to stop or reverse the spindle use the spindle control keys.

Setting the X coordinate

Jog the tool in the X-direction to touch to the outside diameter of the stock.

Jog off the stock in the Z+ direction without moving X. In this example the material is .500 diameter and the tool is in line with that OD. enter the value as follows.

“F7”(T.meas) this will now flash indicating tool offset mode

“X.500” “enter”

“X” “F2” (load)

the X value is now recorded and is displayed on screen.

Setting the Z coordinate

Jog the tool in the Z-direction until you touch the end of the stock.

Then without moving Z, jog off in the X+ direction until the tool is clear. In this example we are allowing .010 facing stock on the end of the material so we will enter the value as follows:

“Z.010” “enter”

“Z” “F2” (load)

The Z value is now recorded and is displayed on screen

To load the next tool you must register the new tool number and go through the same procedure.

When all the tool coordinates are loaded press **“F7”** to exit **“T. meas”** mode.

Tool offsetting

Offsetting the tool in Automatic mode

In Automatic mode there is a Tool Offset choice on the screen.

Press "**F7**" (etc)

Press "**F3**" (T.off)

If this button is pressed a section is displayed at the top of the screen. Enter the tool # you wish to offset and hit "**Recall**" This displays the tool data.

To alter the X or Z offset use "**I**" and "**K**"

To enter a value type in a positive or negative value for I and then press "**K**" press "**Enter**". The I value changed incrementally by the amount you entered.

To adjust for K(Z) enter **K** and a positive or negative value and press "**Enter**"

You must have both I and K entered for this to be accepted by the control.

To finish offsetting a tool press "**F2**"(end)

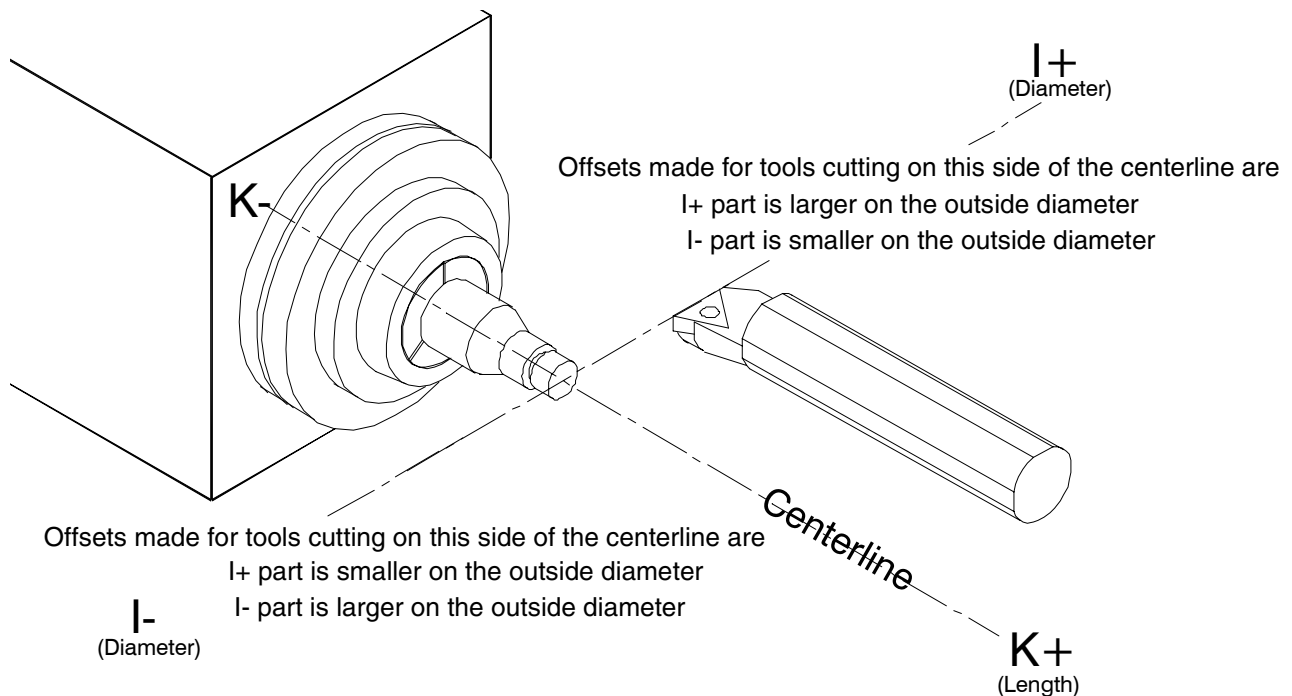

Offset directions(fig 8.1)

Setting a value for Manual operation

To use the control as a DRO (Digital read out) the display can be set to a specific value without using a tool offset.

Once displayed, press the key of the axis on which the present is required.

Key in the required value.

Press **ENTER**. The new value will appear on the screen.

To cancel the preset, before pressing **ENTER**, press **CL** as many times as Characters to be deleted.

To reset the control for program execution return the axis to their home position using home search.

Screen layout for editing

The editing functions and program management and display methods will be covered in this section. You can:

- Create new programs
- Create sub programs
- Create parametric sub programs
- Edit existing programs
- Rename existing programs
- Copy an existing program to create a copy that can be edited without changes to the original.
- Delete existing programs

Press this sequence of buttons to view the editing section:

“**OP MODE**”

“**6**” (editing)

you will see along the bottom of the screen a series of sections with a Function key that corresponds to each choice.

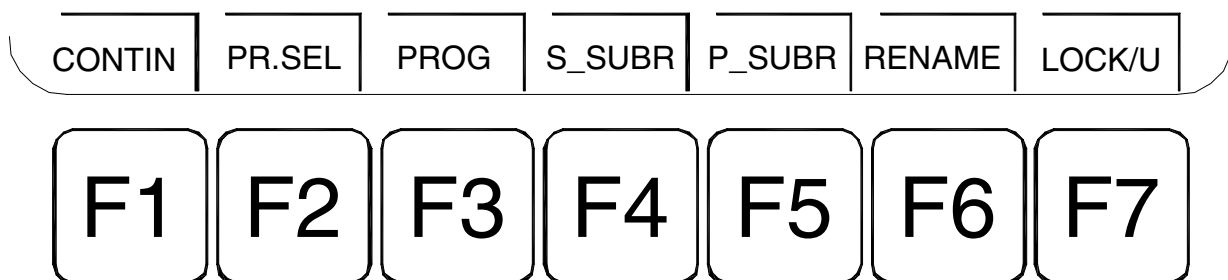

Using the menu prompts

The editing functions can be selected by the menu keys, these keys are explained below:

CONTIN Continue

Press this key to continue after keying in a program #

PR.SEL Program select

This key blanks the program # field and allows a new program to be keyed in.

PROG Program

This displays the list of programs in memory and accesses the screens required to copy delete and rename programs.

S_SUBR Standard subroutine

This displays the list of sub programs in memory and accesses the screens required to copy and delete sub programs.

P_SUBR Parametric subroutine

This displays the list of parametric programs in memory and accesses the screens required to copy and delete programs.

RENAME Rename

This key allows you to rename any program in the memory and give it a different number.

LOCK/U Lock or Unlock

This key allows you to lock access to the programs in the memory.

Starting a new program

Press this sequence of buttons to start a new program:

OP MODE

6 (Editing)

F2 (Program select)

The screen will be blank except for the program # on the top of the screen this will display P00000
Enter the new program #. The new number will be shown in place of P00000.

F1 (Continue)

The screen will now show a split screen with the program number displayed in the top and N0 will be displayed in the lower half of the screen.

You can now enter a program by typing in the required codes.

If you are creating a standard or parametric subprogram you can enter this in the same way.

Accessing an existing program

Press this sequence of buttons to start a new program:

OP MODE

6 (Editing)

F3 (Program)

You can now see the list of programs in the control memory.

Note the program # you want.

F1 (Continue)

This steps you back to the original editing screen.

F2 (Program select)

The screen will be blank except for the program # on the top of the screen this will display P00000
Enter the existing program #. The number will be shown in place of P00000.

F1 (Continue)

The screen will now show a split screen with the program displayed in the upper section, and the 1st block number in the lower section.

Renaming an existing program

Press this sequence of buttons to change the number of an existing program to a different number :

OP MODE

6 (Editing)

F6 (Rename)

The control displays OLD: P

Enter existing program #

ENTER

The control displays NEW: P

enter the new program #

ENTER

Copying an existing program

Press this sequence of buttons to make a duplicate copy of an existing program to a different number:

OP MODE

6 (Editing)

F3 (Program)

You can now see the list of programs in the control memory.

Note the program # you want.

F2 (Copy)

The control displays SOURCE PROGRAM: P

enter existing program #

ENTER

The control displays DESTINATION PROGRAM: P

enter the new program #

ENTER

This creates a copy of the program you selected

Deleting an existing program

Press this sequence of buttons to delete an existing program:

OP MODE

6 (Editing)

F3 (Program)

You can now see the list of programs in the control memory.

Note the program # you want.

DELETE

The control displays DELETE PROGRAM:

enter existing program #

ENTER

This deletes the program you selected

NOTE: All the examples above show the full keystrokes required from the power up passed screen. You can move between screens in edit mode by pressing the continue button.

Using the Dry Run Function

Using the Dry run function to test new programs

The DRY RUN function on the 8025TG controller is very useful for testing new programs, this function is explained below.

Using the Graphics function

There are 4 choices available when DRY RUN is selected on the OP MODE main screen:

- 0 G functions**
- 1 G,S,T,M functions**
- 2 Rapid moves**
- 3 Theoretical Path**

Each selection affects the actuation of the dry run operation differently:

G functions

This function allows the control to execute the program activating all G codes including Tool nose radius compensation,(G40,G41,G42)

G,S,T,M functions

This function allows the control to execute the program activating all G codes including Tool nose radius compensation,(G40,G41,G42) and starting and stopping the spindle and coolant, etc.

Rapid moves

This function allows the control to execute the program at Rapid feedrates regardless of the programmed feedrates.

Theoretical functions

This function allows the control to execute the program without moving the X and Z axis and not using cutter compensation, and displays the center point of the tool tip.

Press this sequence of buttons to use the DRYRUN mode:

OP MODE

4 (Dry Run)

0 (Theoretical path)

The control displays the operation screen that is similar to Automatic mode

Check that the correct program is active.

If not press:

P (enter program #)

RECALL

N

RECALL (to return to start of program)

You can run the program and check for alarms.

To see the graphical path on the screen see the next page.

Using the Graphics Function

Using the Graphics function to test new programs

The graphics function on the 8025TG controller is very useful for testing new programs, this function is explained below.

Graphics function

In Automatic, Single block, and Dry Run modes there is a Function key F6 available.

If The key assignment above F6 is blank the controller is an 8025T (no graphics)

when F6 is pressed the control will ask these questions:

FINAL BLOCK:

N

enter the block that you wish to execute to. If you want to run to the end of the program just press ENTER

If you select a block number the control will prompt you for a program # that the block is in.

Normally you will press enter and run the whole program, if more information is required please refer to the Fagor operators manual.

The next screen will prompt for the center of the window in X and Z and the width of the window.

This is a cross hair view of the work area, the figure below will explain these sizes.

Using the RS232 Communications

Connection to peripheral devices

Press this sequence of buttons to display the choices for communications:

OP MODE

7 (Peripherals)

You can now see a list of options. These are described below:

0 RECIEVE FROM CASSETTE	(Load File From Floppy Drive)
1 SEND TO CASSETTE	(Send File To Floppy Drive)
2 RECIEVE FROM GENERAL DEVICE	(Load From PC)
3 SEND TO GENERAL DEVICE	(Send to PC)
4 CASSETTE DIRECTORY	(Display Programs on Floppy Drive)
5 DELETE CASSETTE PROGRAM	(Delete program from floppy drive)
6 DNC ON/OFF	(DNC selection)

Without a floppy drive only choices 2,3, and 6 are available

Sending an existing program to a PC

If you do not know the program # check the program screen in editing and note the program # to be sent.

Press this sequence of buttons to send an existing program to a PC:

3 (Send to general device)

The control displays PROGRAM NUMBER : P

enter existing program #

ENTER

The control displays

PROGRAM NUMBER : P

sending

When the program has been transmitted the control displays:

PROGRAM NUMBER : P#####

Sending

PROGRAM NUMBER : P##### sent

Press **F1** (continue) to go back to the peripherals screen

Notes:

You must set the PC ready to receive before sending a program.

Each program for a personal computer may be set differently,

Check with you software vendor for any configuration setting before attempting to connect this controller to a computer.

Using the RS232 Communications

Receiving a program from a PC

The controller must be set up before sending a program from a PC

Press this sequence of buttons to receive a program from a PC:

2 (Receive from a general device)

The control displays PROGRAM NUMBER : P

enter new program #

ENTER

The control displays

PROGRAM NUMBER : P#####

No action occurs on the screen, the controller is waiting for a data signal from the PC

The Fagor 8025TG controller requires very specific data formats. The program must start with a % and a 5 digit program #

Example: **%12345**

When the controller receives a % it starts to create a new program with the new number.

If this number is already in memory the control will display:

PROGRAM NUMBER : P#####

ALREADY EXISTS IN MEMORY

DELETE ? (N/Y)

You can delete or not. Or press N or the CL key to return to the peripherals selection screen.

Select a different program #

When the controller is receiving the control displays:

PROGRAM NUMBER : P#####

RECEIVING

If the controller does not end the transmission, and continues to display receiving. The PC has not sent an end of transmission code. This code could be an ASCII 4(EOT) , ASCII 27(ESC) or 20 null codes.

This is a common problem with software that cannot add control codes to the end of transmissions.

Notes:

You must set the Controller ready to receive before sending a program from a PC.

The software must be able to send special ASCII codes at the end of data transmissions.

Check with you software vendor for any configuration setting before attempting to connect this controller to a computer.

If a program has format or data entry errors the control will cease receiving or display errors after the end of transmission code.

EVERY CONTROL IS TESTED PRIOR TO LEAVING OUR FACILITY FOR UPLOAD AND DOWNLOAD.

CABLE CONFIGURATIONS ARE CRITICAL TO SUCCESSFUL TRANSMISSIONS.

90% OF ALL PROBLEMS RELATED TO RS232 ARE PC OR CABLE RELATED.

Section 9

Trigonometry For Programming

Trigonometry solutions

Triangle Calculation

When programming CNC controls, at some point, a calculation of a triangle will be necessary.

This could be a simple taper, or an intersecting radius. The rules of trigonometry help us find a solution to these problems.

The following chapter is designed to help a beginning programmer understand the basics of these trigonometry rules.

Some program calculations are based on right angles triangles, These calculations can appear in many forms. To simplify the solution of these triangles a basic overview is outlined below.

Right Angle Laws

1. One angle is always 90°
2. The sum of the 3 angles in a triangle always equal 180°
3. If one side and one angle are known, the triangle can be solved.
4. If 2 sides of a triangle are known, the triangle can be solved.
5. A triangle consists of 3 angles and 3 sides.
6. If the angle(θ) and one side is known any other angle or side can be found.
7. If two sides are known the angle and third side can be found.

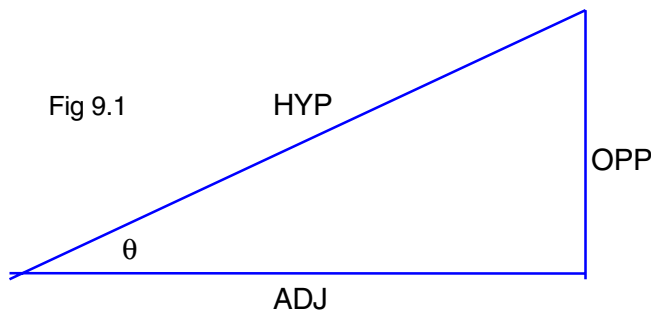

$$\begin{aligned} \sin \theta &= \text{Opp} \div \text{Hyp} \\ \cos \theta &= \text{Adj} \div \text{Hyp} \\ \tan \theta &= \text{Opp} \div \text{Adj} \\ \text{Hyp}^2 &= \text{Opp}^2 + \text{Adj}^2 \end{aligned}$$

No.	To Find	Known	On Scientific Calculator
1	θ	Hyp & Opp	$\text{Opp} \div \text{Hyp} = \text{Arc/Inv Sin}$
2	θ	Hyp & Adj	$\text{Adj} \div \text{Hyp} = \text{Arc/Inv Cos}$
3	θ	Opp & Adj	$\text{Opp} \div \text{Adj} = \text{Arc/Inv Tan}$
4	Opp	θ & Hyp	$\theta \text{ Sin} \times \text{Hyp} =$
5	Opp	θ & Adj	$\theta \text{ Tan} \times \text{Adj} =$
6	Opp	Hyp & Adj	$\text{Hyp}^2 - \text{Adj}^2 = \sqrt{\quad}$
7	Adj	θ & Hyp	$\theta \text{ Cos} \times \text{Hyp} =$
8	Adj	θ & Opp	$\text{Opp} \div (\theta \text{ Tan}) =$
9	Adj	Hyp & Opp	$\text{Hyp}^2 - \text{Opp}^2 = \sqrt{\quad}$
10	Hyp	θ & Opp	$\text{Opp} \div (\theta \text{ Sin}) =$
11	Hyp	θ & Adj	$\text{Opp} \div (\theta \text{ Cos}) =$
12	Hyp	Opp & Adj	$\text{Opp}^2 + \text{Adj}^2 = \sqrt{\quad}$

Note: Nos. 1,2,3. Arc/Inv. Use whichever is shown on you model calculator

Trigonometry solutions

Example 1

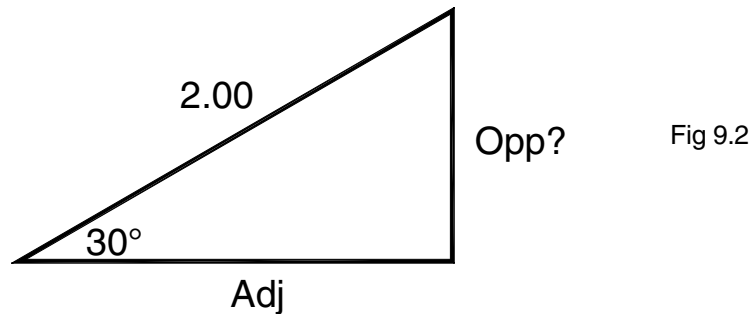

To find the side OPP of sample 1. We look down the second column (To Find) and we see lines 4,5, and 6 contain OPP. We then look in the third column (Known) to see which of lines 4, 5, and 6 contain the remaining 2 elements (θ and HYP).

This narrows our search down to line 4.

On our calculator we enter the angle $\theta(30^\circ)$, press SIN, press the multiply sign X enter the HYP (2), press =. We can now read off the value of the OPP which is 1.0

$$\text{OPP} = 30 \text{ SIN} \times 2.0 = 1.00$$

Example 2

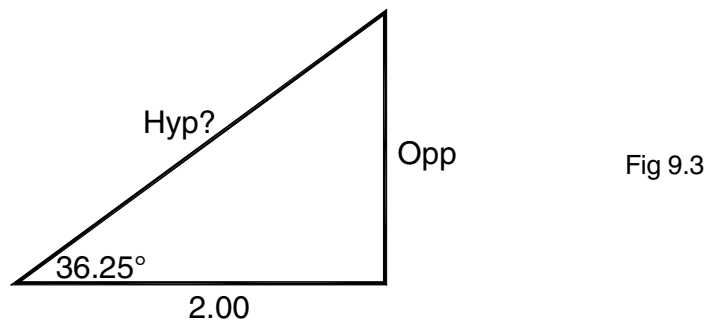

To find the HYP of your sample 2. We look down the (To Find) column and we see lines 10,11 and 12 contain HYP. We check the (Known) column to find the other two elements (θ and ADJ).

This narrows our search down to line 11.

On the calculator enter the ADJ(2), press \div , press(enter the angle θ)36.25, press COS, press), press =

We can now read off the value of the HYP which is 2.4800

$$\text{HYP} = 2 \div (\cos 36.25) = 2.4800$$

Trigonometry solutions

Example 3

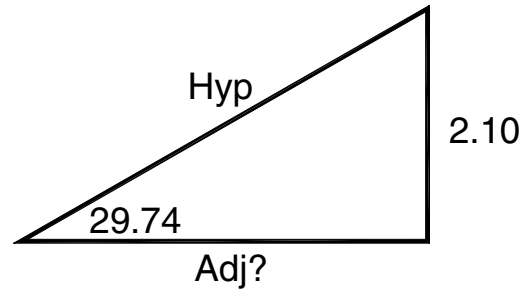

Fig 9.4

To find the **ADJ** of our sample 3. We look down the (To Find) column and see lines 7,8 and 9 contain **ADJ**. We check the (Known) column to find the other two elements (θ and OPP).

This narrows our search down to line 8.

On our calculator we enter the length (OPP) 2.1,press \div , press 29.74, press TAN, press) press =.

We can now read off the value 3.6756

$$\mathbf{ADJ = OPP \div (\theta \text{Tan}) = 3.6756}$$

NOTE:

On modern calculators it may not be necessary to use the() keys since these calculators are capable of selecting mathematical priorities automatically.

You will notice a few "tenths" error in the results. This is due to rounding off the angles to 2 decimal places used in the calculations, the more decimal places used in calculations, the more accurate the results.

Creating Decimal values for Degrees

On most scientific calculators an angle must be input as a decimal.

On newer calculator a Degree, Minute, Second. to Decimal Degree function is included.

If this is not available use this method to convert.

$$\begin{aligned} 30^{\circ} 27' 18'' &= 30.0 + (27/60) + (18/3600) \\ &= 30.0 + (0.45) + (0.005) \\ &= 30.455^{\circ} \end{aligned}$$

Trigonometry solutions

Taper and chamfer calculations

In lathe programming a typical taper is defined by a selection of methods. The most common being described below.

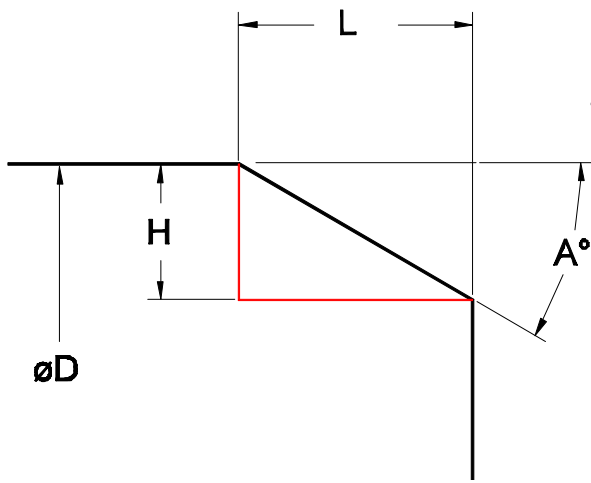

A taper and its variables

Fig 9.5

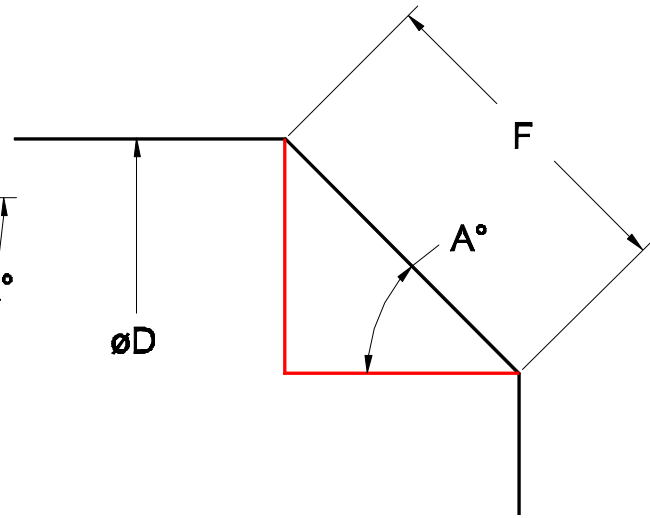

A chamfer and a method of dimensioning

Fig 9.6

To solve for the start and end points, Triangular calculations must be made, and then added or subtracted from the Absolute co-ordinates of the part.

In the examples above a diameter D is given as the absolute diameter. The Z position could be set by the vertical line on the right of the figures.

Fig 9.5 shows a typical taper. Either the height (H) or the length (L) and normally an angle (A) are provided.

Fig 9.6 shows a corner break that has the hypotenuse (F) and an angle (A) provided.

Example 4

We can apply some values to Fig 9.5

The triangle is solved by

$$OPP = 30 \text{ TAN } x \text{ ADJ}$$

$$OPP = 30 \text{ TAN } x 0.25$$

$$OPP = 0.57735 x 0.25$$

$$OPP = 0.1443$$

$$\text{Start position} = 1.6 - (.1443 * 2)$$

$$= 1.6 - .2886$$

$$= 1.3114$$

NOTE:

The value of **OPP** has to be multiplied by 2 to allow for both sides of the part in diameter style programming.

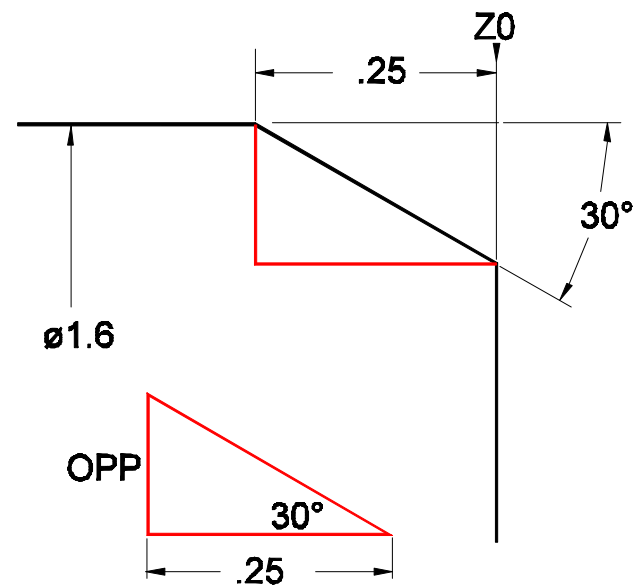

Fig 9.7

Trigonometry solutions

Angular Relationships with Tapers and Radii

When a radius breaks an intersection of a taper on a turned part, a relationship is constructed between the angle and the start and end points of the radius.

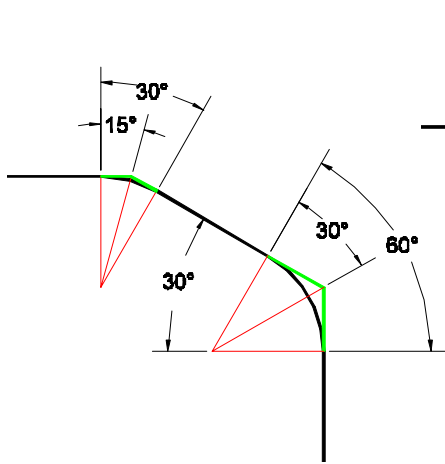

Fig 9.11

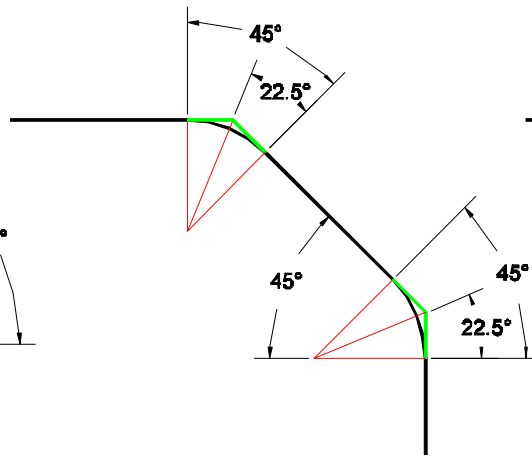

Fig 9.12

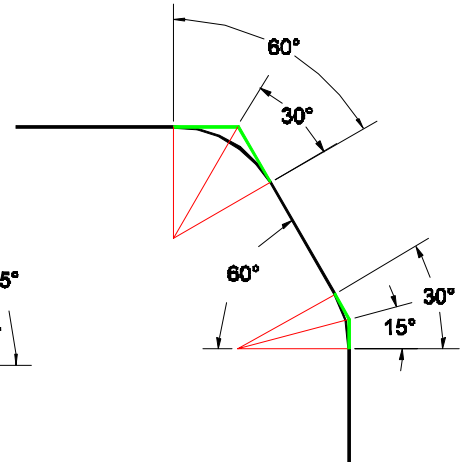

Fig 9.13

3 lines drawn from the center point of the arc, to the intersect points of the arc and corner, create a pair of triangles that are equal and bisect the angle equally. The 3 figures show this relationship.

Calculating Intersect points

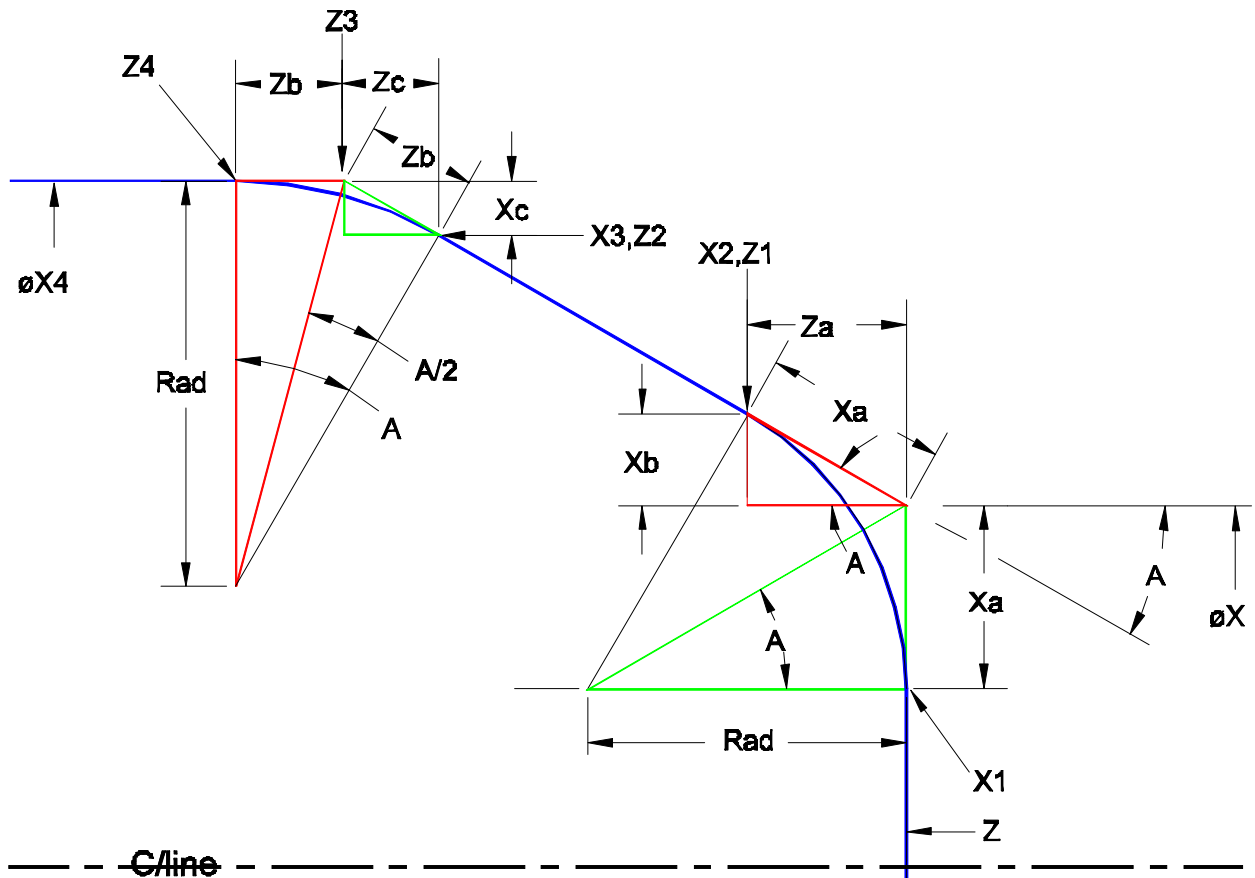

Fig 9.14

Using the rules learned we can define these end points.

Trigonometry solutions

Defining the points

In Fig 9.14 all of the triangles are displayed that are needed to calculate the start and end coordinates for the CNC program.

The main features are Angle A, Diameter X , Diameter X4, and points Z and Z3.

From these points, or a combination of these points, the program can be calculated.

An example (fig 9.15) with dimensions will be used to explain these calculations.

Example 7

Dimensioned part

Fig 9.15

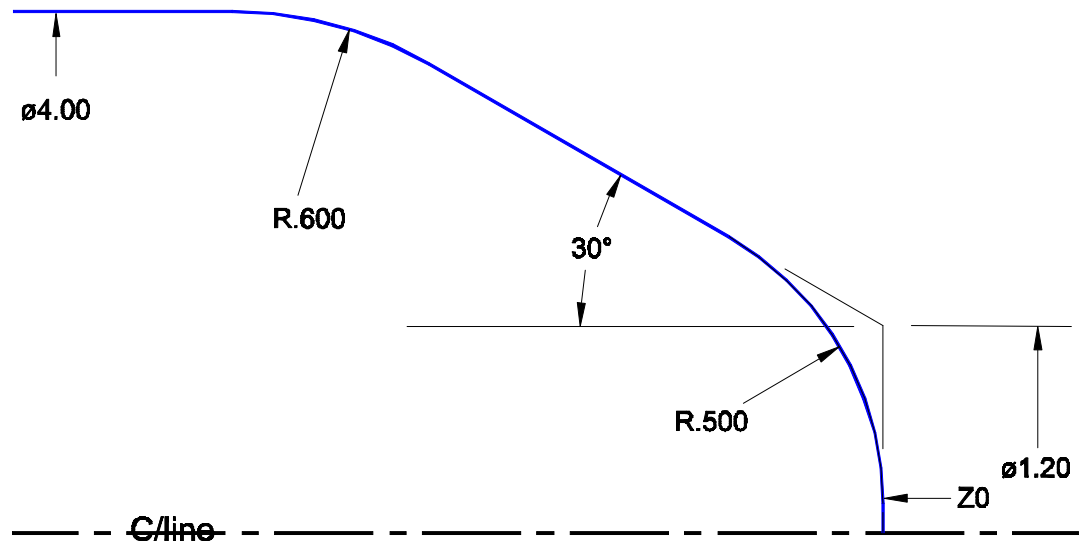

This shows a typical part and related dimensions.

The 1st calculation is to determine point Z3

Remember that an X axis triangle side is a radial value. Diameters have to be divided in half.

$$\begin{aligned} \text{Opp} &= (X4-X)/2 \\ &= (4.00-1.200)/2 \\ &= 2.8/2 \\ \text{Opp} &= 1.4 \end{aligned}$$

$$\begin{aligned} \text{Adj} &= \text{Opp} \div \text{Tan } A \\ &= 1.40 \div \text{Tan } 30 \\ &= 1.40 \div 0.5773 \\ \text{Adj} &= 2.4250 \end{aligned}$$

$$\begin{aligned} Z3 &= Z3 - Z \\ &= 2.425 - 0 \end{aligned}$$

$$Z3 = 2.425$$

Fig 9.16

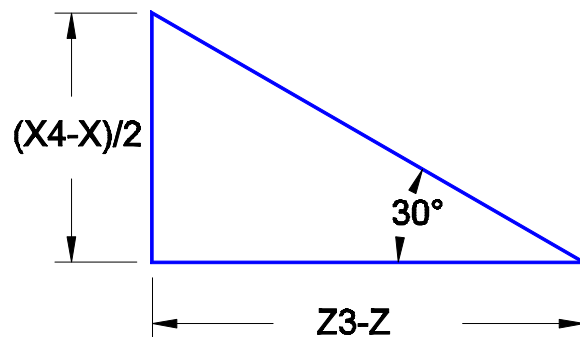

Trigonometry solutions

Defining the 1st corner points

The 2nd calculation is to find point X1

$$X_a = \text{Opp}$$

Use this solution

$$\begin{aligned}\text{Opp} &= \text{Tan } A \times \text{Adj} \\ X_a &= \text{Tan } 30 \times .5 \\ &= .5773 \times .5\end{aligned}$$

$$X_a = 0.2886751$$

Therefore

$$\begin{aligned}X_1 &= X - 2(X_a) \\ &= 1.2 - 2(0.2886751) \\ &= 1.2 - 0.5773 \\ X_1 &= 0.6227\end{aligned}$$

Because the 2 triangles are equal that bisect the radius. The Opp side X_a is the Hyp side in the 2nd triangle.

The 3rd calculation is to find point Z_a

$$Z_a = \text{Adj}$$

Use this solution

$$\begin{aligned}\text{Adj} &= \text{Cos } A \times \text{Hyp} \\ &= \text{Cos } 30 \times X_a \\ &= 0.8660 \times 0.2886751\end{aligned}$$

$$\text{Adj} = 0.2500$$

Therefore

$$\begin{aligned}Z_1 &= Z + Z_a \\ &= 0 + 0.25 \\ Z_1 &= 0.25\end{aligned}$$

The 4th calculation is to find point X_b

$$X_b = \text{Opp}$$

Use this solution

$$\begin{aligned}\text{Opp} &= \text{Sin } A \times \text{Hyp} \\ &= \text{Sin } 30 \times X_a \\ &= 0.5000 \times 0.2886751\end{aligned}$$

$$\text{Opp} = 0.1443$$

Therefore

$$\begin{aligned}X_2 &= X + 2(X_b) \\ &= 1.2 + 2(0.1443) \\ &= 1.2 + 0.2886 \\ X_2 &= 1.4886\end{aligned}$$

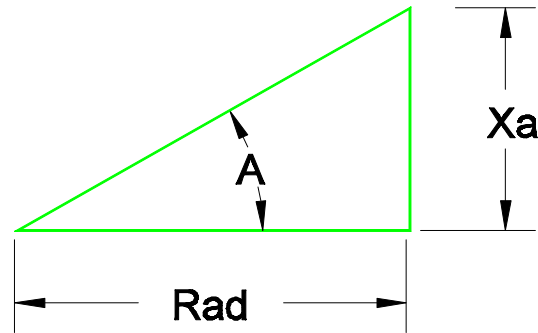

Fig 9.17

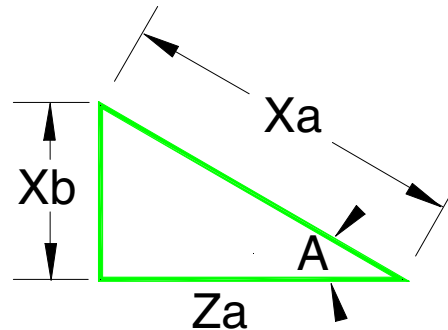

Fig 9.18

Trigonometry solutions

Defining the 2nd corner points

The main difference in the next group of calculations is that the angle A is divided in half.

If you study the figures 9.11 through 9.13 you will see that as the angle increases to 45° the relationship between the part angle and the bisecting triangles change. Before 45° the 1st angle stays at the part angle, After 45° the 1st angle is half the part angle.

In the Calculations that follow the angle will be 15°

The 5th calculation is to find point Zb

$$Zb = Opp$$

Use this solution

$$\begin{aligned} Opp &= \tan A \times Hyp \\ &= \tan 15 \times Rad \\ &= 0.26794 \times 0.600 \end{aligned}$$

$$Opp = 0.1607$$

From the 1st calculation Z3 = 2.425

Therefore

$$\begin{aligned} Z4 &= Z3 + Zb \\ &= 2.425 + 0.1607 \\ Z4 &= 2.5857 \end{aligned}$$

The 6th calculation is to find point Xc

$$Xc = Opp$$

Use this solution

$$\begin{aligned} Opp &= \tan A \times Hyp \\ &= \tan 30 \times 0.1607 \\ &= 0.5773 \times 0.1607 \end{aligned}$$

$$Opp = 0.09278$$

Therefore

$$\begin{aligned} X3 &= X4 - 2(Xc) \\ &= 4.00 - 2(0.09278) \\ &= 4.00 - 0.18556 \\ X3 &= 3.8144 \end{aligned}$$

Finally To find point Zc

$$Zc = Adj$$

Use this solution

$$\begin{aligned} Adj &= \cos A \times Hyp \\ &= \cos 30 \times 0.1607 \\ &= 0.8660 \times 0.1607 \end{aligned}$$

$$Adj = 0.1391$$

Therefore

$$\begin{aligned} Z2 &= Z3 - Zc \\ &= 2.425 - 0.1391 \\ Z2 &= 2.2858 \end{aligned}$$

Fig 9.19

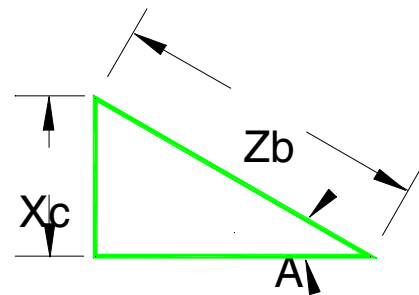
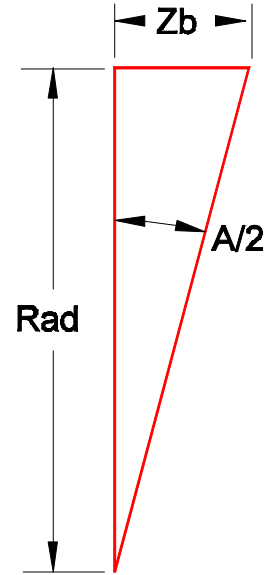

fig 9.20

Trigonometry solutions

Creating the Program

The co-ordinates that have been calculated can now be used to generate the program.

%00112	%00112
N00 G90 G95 S1200 T1.1 M3	N00 G90 G95 S1200 T1.1 M3
N10 G00 X0.2 Z1.0	N10 G00 X0.2 Z1.0
N20 G42 X0 Z0.5	N20 G42 X0 Z0.5
N30 G01 Z F.005	N30 G01 Z0 F.005
N40 G01 X1	N40 G01 X0.6227
N50 G03 X2 Z1 R	N50 G03 X1.4886 Z-.25 R0.5
N60 G01 X3 Z2	N60 G01 X3.8144 Z-2.2858
N70 G03 X4 Z4 R	N70 G03 X4.00 Z-2.5857 R0.6
N80 G00 G40 X?	N80 G00 G40 X?

Non Axis parallel angles

When programming non axis parallel moves, additional calculations have to be made this example shows the extra Zc amount that has to be calculated. Other calculations also have to be made to allow for the angular position of the intersect points.

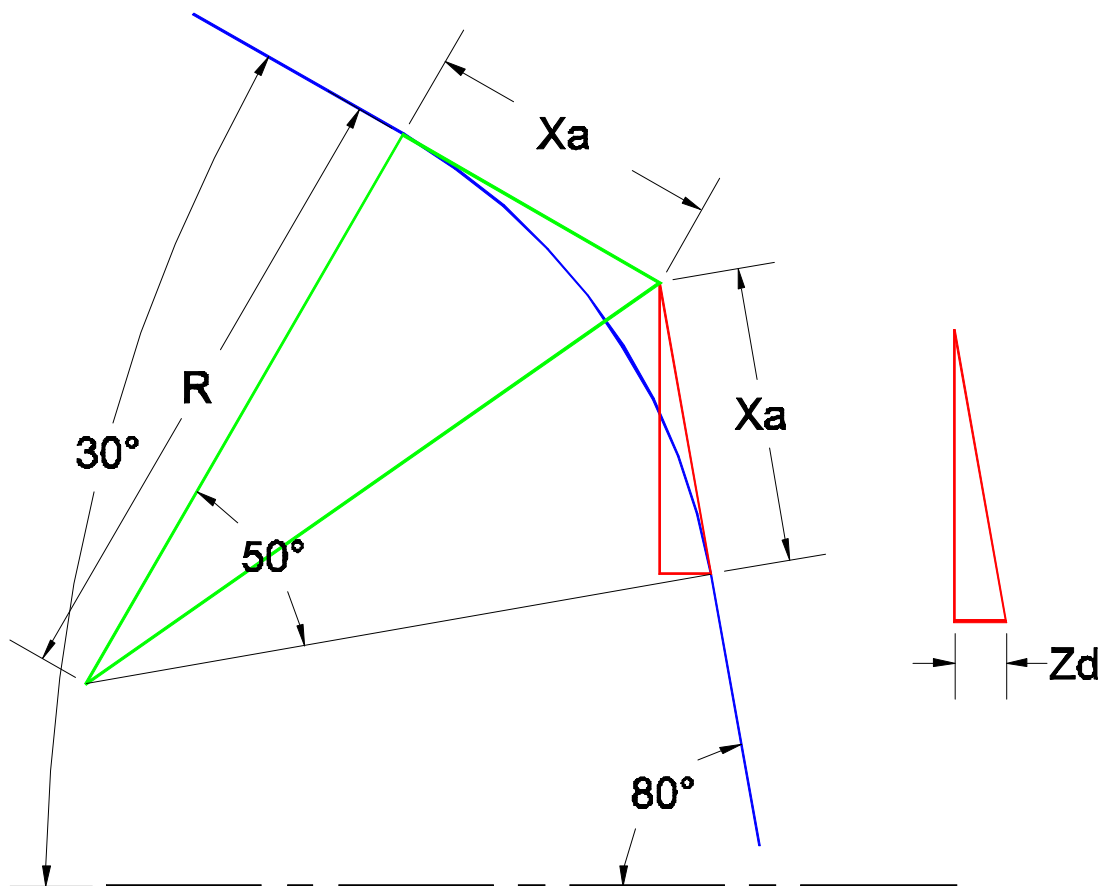

Fig 9.21

Note the relationship that the angled lines form with the interior angles of the bisecting triangle. If this seems like a lot of programming for such a simple shape, Please refer to section 10 (Advanced features for programming) for an explanation of special functions available with the Fagor 8025TG controller.

Trigonometry solutions

Circle problems

A common problem in turning is producing a partial radius on a shaft, This can be solved with the formula for circular segments.

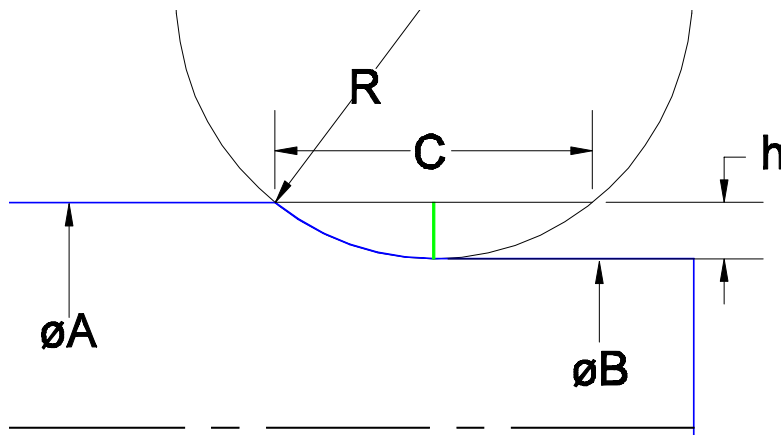

Fig 9.21

If we know the diameters A & B the height h can be simply calculated

$$h = (A-B)/2$$

Example 8

A shaft having a Diameter A=1.5 and a diameter B=.75 with a blending radius R=2.0 starting at Z-1.5 Calculate the blend position in Z for the A diameter and the arc R.

Use this solution

$$\begin{aligned} h &= (A-B)/2 \\ &= (1.5-.75)/2 \\ &= .375 \\ C &= 2 \sqrt{h(2R - h)} \\ &= 2 \sqrt{.375(2 \times 2 - .375)} \\ &= 2 \sqrt{.375(3.625)} \\ &= 2 \sqrt{1.359375} \\ &= 2 \times 1.165922 \\ &= 2.3318 \end{aligned}$$

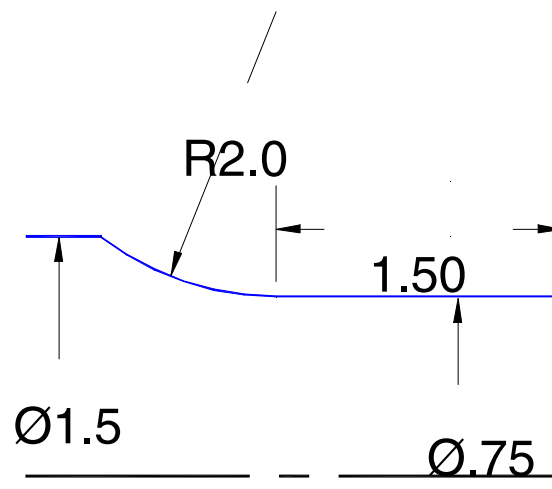

Fig 9.22

Divide C by 2 for half the chord length and add to Z-1.5

$$Z-1.5+ (-1.1659) = Z-2.6659$$

Section 10

Advanced Features for Programming

Advanced Features for Position Input

Cartesian Coordinates

In an earlier section we discuss Absolute and Incremental coordinates. This is referred to as a Cartesian coordinate system.

Using the extended features in Cartesian coordinates allow us to provide a method of programming that greatly simplifies the process of cutter path generation.

This section explains this feature and its limitations.

Angles Coordinates

The control allows the input of angles with Cartesian coordinates.

The example below shows the orientation of these angle coordinates:

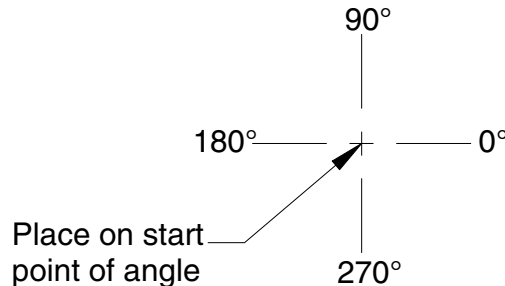

Angles and X Coordinates

Using this feature in your programs allows the ability to use 1 coordinate position and an angle the example below demonstrates this:

```
G00 X0 Z0.1  
G01 Z0  
G01 X0.100  
G01 X0.500 A150.  
G01 Z-?.
```

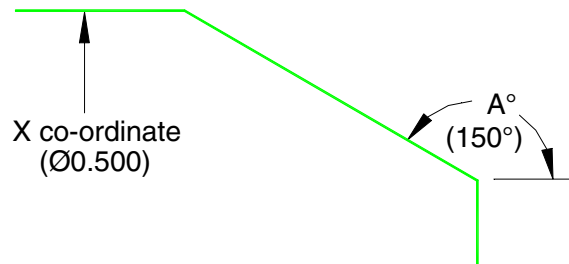

This profile would require a triangle to be calculated for the Z end point of the angle, if using X & Z positions. This may not appear to be of great advantage, but it can be combined with radius corners and chamfering. This is shown in the next example:

Angles, Radii and X Coordinates

```
G00 X0 Z.1  
G01 Z0  
G01 G36 R.05 X0.100 A90.  
G01 G36 R.2 X0.500 A150.  
G01 Z-?.
```

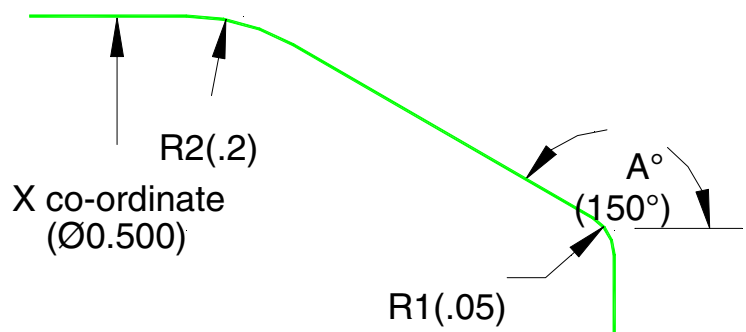

As you can see this reduces the amount of calculation for programming.

Parametric Programming

Operations with parameters

The CNC has 255 parameters (P0-P254) with which the programming of parametric blocks can be performed as well as different types of operations and jumps within a program.

Parameters P000-P019 are used for canned cycles and are not to be used as variables.

Parametric blocks can be written in any part of the program.

All math functions should be grouped at the head of the program.

The operations which can be made between parameters are as follows:

F1	Addition
F2	Subtraction
F3	Multiplication
F4	Division
F5	Square Root
F6	Square root of the addition of the squares
F7	Sinus
F8	Cosine
F9	Tangent
F10	Arc Tangent
F11	Comparison
F12	Entire Value
F13	Entire Value plus one
F14	Entire Value minus one
F15	Absolute value
F16	Complementation
F17	Special functions
F18	Special function
F19	Special functions
F20	Special functions
F21	Special functions
F22	Special functions
F23	Special functions
F24	Special functions
F25	Special functions
F26	Special functions
F27	Special functions
F28	Special functions
F30	AND
F31	OR
F32	XOR
F33	NOR
F34	Special functions
F35	Special functions

These functions are not covered in this manual.

Please refer to the Fagor programming manual for complete explanations of these features.

There are some uses explained in G25 conditional jump.

Section 11

Manual tool nose radius Compensation

Tool nose compensation

Manual Calculation

When you select an indexable insert to machine a part, it will normally have a radius on the tip, This tip is called the Tool nose Radius.

As you create a program for a CNC lathe, some moves need tool nose radius compensation.(TNRC) and some do not

In this section we will explain how and when to apply these calculations.

Theoretical Sharp Point

The basic concept of programming is to calculate a tool path based on a known shape.

This shape is the part profile. Without using tool nose radius compensation(G41-G42)you have to alter the tool path to allow for the tool nose radius.

Most lathe programming is done using the concept of theoretical sharp point.

With this method the known point is called the Theoretical sharp point. This is a position axis tangent to the tool radius in X & Z .

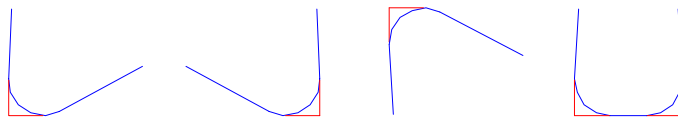

Right hand, left hand, boring and grooving tips(fig 10.1)

If you are using a reverse tool or a boring bar, the Theoretical sharp point will be in a relative position to the orientation of the tool. A grooving tool can have 2 points to program.

Calculation and application

Any axis parallel moves do not have to have tool nose radius compensation (TNRC) applied to them.

The bottom and side of the insert moves along the desired path and create a part with no angles or radii.

The positions in the program will be the same positions that are on the part drawing, A diameter of 2.0" will be X2.0. A length on Z of 1.5" will be Z-1.5(assuming Z0 is the face of the part)

The example below shows this :

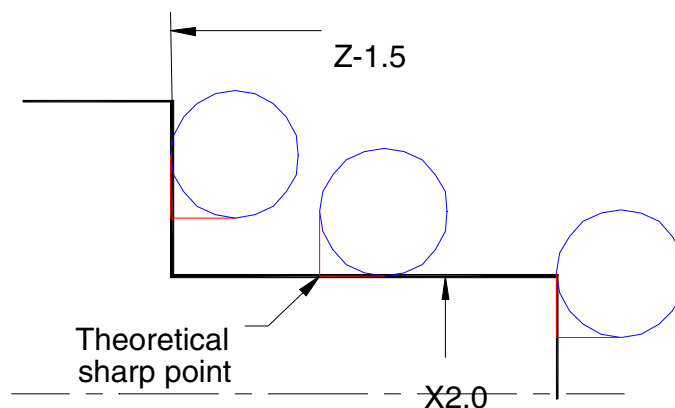

Axis parallel moves (fig 10.2)

Tool nose compensation

Types of Calculation

There are calculations for Radii, Tapers, reverse tapers(rear of the tool tip) and combinations of both these will be explained in the following section.

Radius Calculation

When a radius is required TNRC has to be applied.

The basic rule is as follows :

An external radius has the Tool Nose Radius added to it.

An internal radius has the Tool Nose Radius subtracted from it.

The example below shows this :

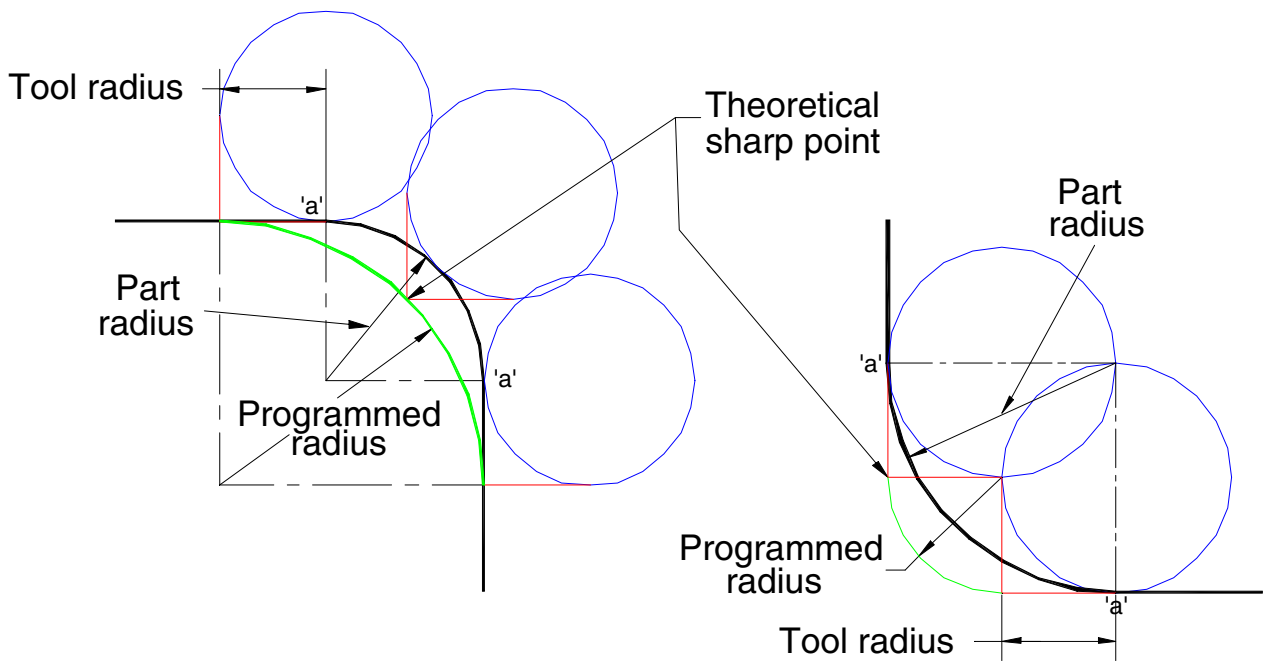

External and Internal radius compensation(fig 10.3)

In the example above the Theoretical start and end points are calculated based on the fact that the tangent point for 2 radii is always through their center.(points 'a')

In the external radius we add the tool nose radius to the part radius and then calculate the actual start and end points.

External Radius Calculation

If a radius of .25 is required on the external corner of a part and the tool nose radius is .031 the programmed radius will be:

$$.25+.031=.281$$

If the radius is on a 1.0 diameter and at the Z0 face of the part the program will follow the example below.

G1 X0 Z0

Start of part profile

G1 X.438

$1.0-(.281 \times 2)=.438$ (see note)

G3 X1.0 Z-.281 R.281

Move to the X and Z axis end point of the arc with the R value.

G1 Z-?

Next axis parallel move

Tool nose compensation

Internal Radius Calculation

If a radius of .25 is required on the internal corner of a part and the tool nose radius is .031 the programmed radius will be :

$$.25-.031=.219$$

If the radius is on a 1.0 diameter and at the Z0 face of the part the program will follow the example below.

G1 X1. Z0 Start of part profile
G1 Z-.781 Start of radius
G2 X1.438 Z-1. R.219 $1.0+ (.219 \times 2) = 1.438$ (see note)
G1 X-? Next axis parallel move

NOTE:

When calculating the end points in a part program you must double the X axis calculation to allow for both sides of the part. Any trigonometry calculation is only generating a radial value for X.

Taper Calculation

To simplify tool radius compensation on tapers a chart is provided that gives a range of radii and angles between 0° - 45° . If a radius greater than 45° is encountered simply use the opposite angle in the triangle and reverse the Xc and Zc values.

If an angle has to be calculated the formula is described below :

$$\text{TNRC for X} = R - (\tan \theta \times R)$$

Triangle development :

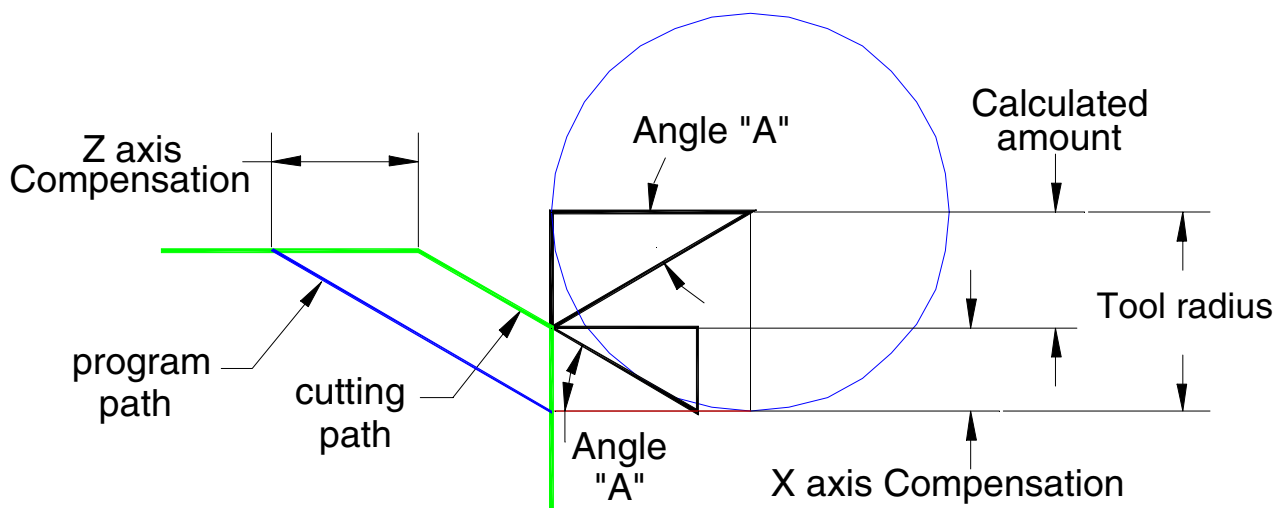

Tool radius comp for angles(Fig10.4)

Tool nose compensation

Taper Calculation

If the angle is 30° and the radius is .03125”

The X axis calculation is : **$X = R - (\tan \theta \times R)$**

$$X = .03125 - (\tan 30 \times .03125)$$

$$X = .03125 - (.57735 \times .03125)$$

$$X = .03125 - (.01804)$$

$$X = .013207$$

TNRC for Z = $\frac{\text{Compensation in X}}{\tan \theta}$

The Z axis calculation is : **$Z = \frac{.013207}{.57735}$**

$$Z = .02287$$

If these calculations are compared to your chart the numbers match.

In practice it is far easier to use a chart and apply one axis of compensation, and then calculate the end point of the other axis. This method ensures that the correct angle is machined, and any rounding of numbers is taken into consideration.

Tool nose compensation chart

ANGLE	0.005"Radius		0.007"Radius		0.010"Radius		1/64"Radius		1/32"Radius	
	Xc	Zc	Xc	Zc	Xc	Zc	Xc	Zc	Xc	Zc
1	.000087	.004956	.000121	.006939	.000173	.009913	.000270	.015489	.000541	.030868
2	.000172	.004913	.000240	.006878	.000343	.009825	.000536	.015352	.001072	.030704
3	.000258	.004869	.000357	.006817	.000510	.009738	.000797	.015216	.001595	.030432
4	.000337	.004825	.000472	.006758	.000675	.009651	.001054	.015079	.002109	.030159
5	.000418	.004782	.000586	.006694	.000837	.009563	.001307	.014943	.002615	.029886
6	.000498	.004738	.000697	.006633	.000996	.009476	.001556	.014906	.003112	.029612
7	.000576	.004694	.000807	.006572	.001153	.009388	.001801	.014894	.003602	.029339
8	.000654	.004650	.000915	.006511	.001307	.009301	.002042	.014532	.004065	.029065
9	.000730	.004606	.001021	.006449	.001459	.009213	.002260	.014395	.004580	.028791
10	.000804	.004563	.001126	.006388	.001609	.009125	.002514	.014258	.005028	.028516
11	.000878	.004519	.001230	.006326	.001757	.009037	.002745	.014121	.005489	.028241
12	.000951	.004474	.001331	.006264	.001902	.008949	.002972	.013983	.005944	.027966
13	.001023	.004430	.001432	.006202	.002046	.008861	.003196	.013845	.006393	.027690
14	.001094	.004386	.001531	.006141	.002187	.008772	.003417	.013707	.006835	.027413
15	.001163	.004342	.001629	.006078	.002327	.008683	.003835	.013568	.007271	.027136
16	.001232	.004297	.001725	.006016	.002464	.008595	.003851	.013429	.007701	.026858
17	.001300	.004253	.001820	.005954	.002600	.008506	.004063	.013290	.008126	.026580
18	.001367	.004208	.001914	.005891	.002735	.008416	.004273	.013150	.008545	.026301
19	.001434	.004183	.002007	.005829	.002867	.008327	.004480	.013010	.008959	.026021
20	.001499	.004118	.002099	.005766	.002998	.008237	.004684	.012870	.009388	.025740
21	.001564	.004073	.002189	.005703	.003127	.008147	.004886	.012729	.009772	.025458
22	.001627	.004028	.002278	.005639	.003255	.008056	.005086	.012588	.010171	.025178
23	.001691	.003983	.002367	.005576	.003381	.007966	.005283	.012446	.010566	.024892
24	.001753	.003937	.002454	.005512	.003506	.007874	.005478	.012304	.010958	.024608
25	.001845	.003892	.002540	.005448	.003629	.007763	.005671	.012161	.011341	.024322
26	.001876	.003846	.002626	.005384	.003751	.007691	.005861	.012018	.011723	.024036
27	.001936	.003800	.002710	.005319	.003872	.007599	.006050	.011874	.012190	.023746
28	.001996	.003753	.002794	.005255	.003991	.007507	.006236	.011729	.012473	.023459
29	.002065	.003707	.002877	.005190	.004109	.007414	.006421	.011584	.012542	.023188
30	.002113	.003660	.002959	.005124	.004226	.007321	.006604	.011438	.013208	.022877
31	.002171	.003613	.003040	.005089	.004342	.007227	.006785	.011292	.013568	.022584
32	.002228	.003586	.003120	.004993	.004457	.007133	.006984	.011145	.013928	.022269
33	.002285	.003519	.003199	.004927	.004570	.007038	.007141	.010997	.014282	.021994
34	.002341	.003471	.003278	.004880	.004683	.006943	.007317	.010848	.014634	.021696
35	.002397	.003424	.003356	.004793	.004794	.006847	.007491	.010699	.014982	.021397
36	.002452	.003375	.003433	.004726	.004905	.006751	.007664	.010548	.015327	.021096
37	.002507	.003327	.003510	.004658	.005014	.006654	.007835	.010397	.015689	.020794
38	.002561	.003278	.003586	.004590	.005123	.006557	.008004	.010245	.016008	.020490
39	.002615	.003229	.003661	.004521	.005230	.006459	.008172	.010092	.016344	.020184
40	.002668	.003180	.003736	.004452	.005337	.006360	.008339	.009938	.016678	.019876
41	.002721	.003131	.003810	.004383	.005443	.006261	.008504	.009783	.017008	.019586
42	.002774	.003081	.003883	.004313	.005548	.006181	.008668	.009627	.017336	.019254
43	.002826	.003030	.003956	.004243	.005652	.006061	.008831	.009312	.017985	.018941
44	.002878	.002980	.004029	.004172	.005755	.005960	.008992	.009312	.017985	.018624
45	.002929	.002929	.004100	.004101	.005858	.005858	.009153	.009153	.018306	.018306

For Lathe compensation MULTIPLY Xc*2 (Diameter programming)

For angles over 45° subtract from 90°(Angle = 53° use 37°) (53+37=90) Xc=Zc Zc=Xc

Tool nose compensation

Toolnose compensation when profiling with the rear of the tool

For most rear profiling applications a groove or recess is produced and the compensation takes place in Z. Only the programmed end points are modified from the part size. X axis points stay the same.

A simple calculation is all that is needed for rear profiling in Z axis.

$$\text{Compensation in Z} = R + (\text{Sine } \theta \times R)$$

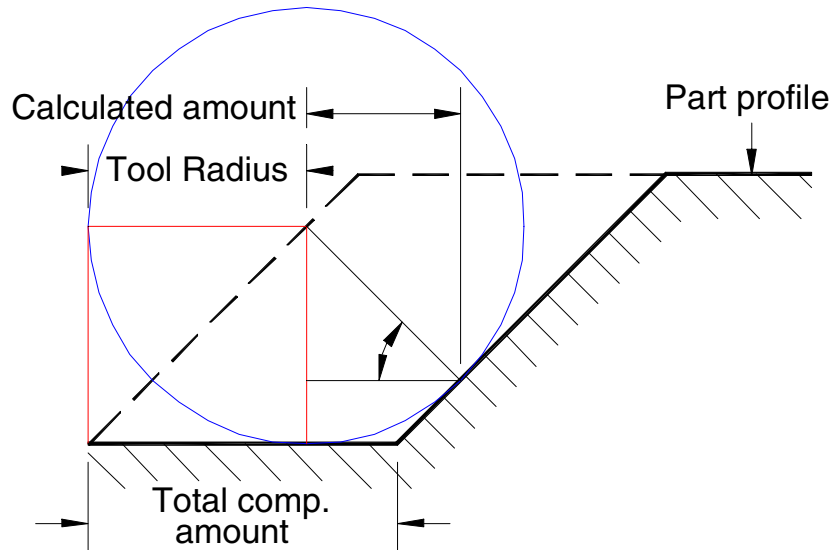

Rear profile compensation(Fig 10.5)

Rear Taper Calculation

Examples :

Using a 0.03125 Radius tool and a 45° angle

$$\begin{aligned} \text{Compensation in Z} &= R + (\text{Sine } \theta \times R) \\ &= 0.03125 + (\text{Sin}45 \times .03125) \\ &= 0.03125 + (.7071 \times .03125) \end{aligned}$$

$$\mathbf{Z = 0.0533}$$

Using a 0.015 Radius tool and a 45° angle

$$\begin{aligned} \text{Compensation in Z} &= R + (\text{Sine } \theta \times R) \\ &= 0.015 + (\text{Sin}45 \times .015) \\ &= 0.015 + (.7071 \times .015) \end{aligned}$$

$$\mathbf{Z = 0.0256}$$

Using a 0.015 Radius tool and a 30° angle

$$\begin{aligned} \text{Compensation in Z} &= R + (\text{Sine } \theta \times R) \\ &= 0.015 + (\text{Sin}30 \times .015) \\ &= 0.015 + (.5 \times .015) \end{aligned}$$

$$\mathbf{Z = 0.0225}$$

Appendix 1

Control Parameters

Standard Parameter Settings

SYSTEM (REV. A — 5/1/98)

Standard model (No indexing or “C” axis)

P#	Description	Set Value
P000	BAUD RATE	9600 *
P001	# OF BITS	8 *
P002	PARITY	0 (No) *
P003	STOP BITS	1 *
P004	FEEDRATE @ G00	Y
P005	POWER FREQ.	60
P006	THEO/REAL	0 (Real)
P007	SPEED S1	4500
P008	SPEED S2	4500
P009	SPEED S3	4500
P010	SPEED S4	4500
P011	RAD/DIA	1 (Diameter)
P012	CONT. JOG	Y
P013	MM / IN	1 (Inches)
P099	LANGUAGE	2 (English)

* Set these parameters to match the connected device

X AXIS

P#	Description	10 Pitch	5 Pitch
P100	CHANGE LP SIGN	Y	
P101	CHANGE AXIS SIGN	Y	
P102	CHANGE JOG SIGN	Y	
P103	SCALE RES	1	
P104	DWELL	N	
P105	CONTINUOUS	Y	
P106	SENOIDAL	N	
P107	SOFT + LIMIT	Set to machine	
P108	SOFT - LIMIT	Set to machine	
P109	BACKLASH	0	
P110	MAX FEED	2000	
P111	MAX G00	6000	6000
P112	ZERO SET SPD	250	
P113	BACKLASH AO	0	
P114	K1	56	16
P115	DISCONTINUITY	1100	12900
P116	K2	39	16
P117	MIN AO	1	
P118	DEAD BAND	10	
P119	REF. MARK	0.0000	
P200	NOT USED		

Standard Parameter Settings

Z AXIS

P#	Description	10 Pitch	5 Pitch
P300	CHANGE LP SIGN	Y	
P301	CHANGE AXIS SIGN	Y	
P302	CHANGE JOG SIGN	N	
P303	SCALE RES	1	
P304	DWELL	N	
P305	CONTINUOUS	Y	
P306	SENOIDAL	N	
P307	SOFT + LIMIT	Set to machine	
P308	SOFT - LIMIT	Set to machine	
P309	BACKLASH	0	
P310	MAX FEED	2000	
P311	MAX G00	6000	6000
P312	ZERO SET SPD	250	
P313	BACKLASH AO	0	
P314	K1	56	16
P315	DISCONTINUITY	1100	12900
P316	K2	39	16
P317	MIN AO	1	
P318	DEAD BAND	10	
P319	REF. MARK	0.0000	
P400	NOT USED		
P500	CHANGE AXIS SIGN	N	
P501	SCALE RES	10	

Standard Parameter Settings

Binary parameters

When changing or reading binary parameters please remember that the data is always read from right to left.

Example:

P602=00001111

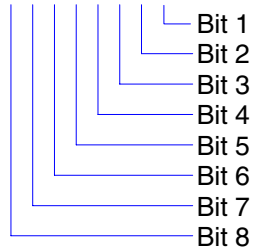

P#	Binary Value 10 Pitch	Binary Value 5 Pitch
P600	11100000	
P601	01000000	
P602	00110001	00110111
P603	00001111	
P604	00001000	
P605	10111000	11110000
P606	00001000	
P607	01001000	
P608	00000001	
P609	00000001	
P610	00000000	
P611	00000000	
P612	00000000	
P613	00001000	
P614	01100000	
P615	00010001	
P616	00000000	
P617	00000000	
P618	10000000	
P619	00000000	
P620	00000000	
P621	00000000	
P622	00000000	
P623	00000000	
P700	99	
P701 thru P703	0	
P704	20	80
P705 thru P711	0	
P712	4	6
P713	4	6
P714 thru P741	0	
P800	1024	
P801 thru P823	0	
P900 thru P923	0.0000	

Standard Parameter Settings

Reversing X axis travel direction

On a gang tooled lathe the X axis can be set with the positive direction of movement in either direction of axis travel.

Some users prefer the X positive direction to be away from the operator, some users prefer the X positive direction to be towards the operator.

Regardless of your specific setup, If you wish to change this direction follow the directions below.

Read through these directions and follow the keystrokes on your control so that you understand the procedure. Write down the settings of parameters:

100, 101, 107, 108, 618.

Power up the machine and press these keys:

1. **Op Mode key**
2. **9** (Special mode)
3. **1** (General parameters)
4. Enter **100** press **Recall**

The parameters P100 and P101 control the X axis link to the servo's.

The setting may be Y or N on each parameter.

Change each one from Y to N, or N to Y depending on there active state.

Warning: Parameters 100 and 101 must both be changed BEFORE returning to a machine positioning mode, either jog(5) automatic(0), or single block(1). This will cause the machine to go into an axis runoff mode which could cause equipment damage and operator injury.

To change these parameters enter these key strokes:

1. **100=Y or N**
2. **Enter**
3. **101=Y or N**
4. **Enter**

Next change the soft limits. Parameters 107 and 108. These are reversed, 107 becomes 108, and 108 becomes 107.

107 is always a positive value, with this format **107=XXX.XXXX** no positive sign.

108 is always a negative value, with the format **108=-XXX.XXXX** always with a negative sign.

If **P107=006.4400** and **P108=-004.8800** after the change they will be:

P107=004.8800 and **P108=-006.4400.**

Next change the home search direction. Parameter 618. This is an 8 bit parameter. It will either be:

10000000 or **00000000**. Change this to :

00000000 or **10000000**.

Press 618=10000000 or **618=00000000** press **Enter** to load.

After these parameters have been changed either press **RESET 3 times** or turn the power off and restart the machine.

Standard Parameter Settings

Reversing X axis Graphics direction(Fagor 8025 TG)

This function is controlled by 2 bits in parameter P606. Bits 4 and 5 determine the axis display direction.

With the X positive direction towards the back of the machine set parameter P606 as follows:

P606 bit 4 = 0 bit 5=0

With the X negative direction towards the back of the machine set parameter P606 as follows:

P606 bit 4 = 1 bit 5=0

Reversing the G02 and G03 directions

When changing axis direction the interpolation direction changes, this requires parameter **P600 bit 1** to be changed.

If the machine runs the **G02** and **G03** in the wrong direction, change this parameter.

P600=0000001 change to P600=0000000

P600=0000000 change to P600=0000001

Appendix 2

Amplifier Information

Amplifiers

Upgrade Technologies, Inc. currently uses the following amplifiers

Servo Dynamics SDFCC 1020-12
21541 D. Nordhoff St.
Chatsworth, CA 91311
(818) 700-8600

Servo Dynamics Specifications

Peak Voltage	± 118 VDC	Peak Current	± 20 amps
Continuous Voltage	± 112 VDC	Continuous Current	± 10 amps
Horsepower (cont.)	.75 HP	Input power req.	Bus 15 to 120 VDC
Signal input voltage	± 10 volts (typ.)	Signal input voltage	± 35 volts (max.)
Gain	0-5100 amps/v	Signal input imped.	40K min.
Drift	10 μ V/°C	Switching frequency	16 kHz
Bandwidth	2.0 kHz	Current Limit (adj.)	0 to peak amps
RMS limit (adj.)	0% to 100% Cont.	Ambient Temp (op)	0° to 50°C
Max heatsink Temp	70°C w/blower	Dimensions	L=6.2", W=0.9", H=4.5"

Specification notes:

- Maximum peak current available for 1 second.
- The amplifier has a built-in RMS protection circuit. If the continuous current level is exceeded for an extended time, the amplifier will trip-off.
- The amplifier, when tripped, will stay off with an LED indication.
- Buffered current output can drive a 5K or greater load (bi-directional)
- Minimum load inductance must be 1.2 MHz for safe operation.

Servo Faults

This model is protected against several fault conditions that may occur and these are as follows:

The LED is a three color LED that indicates status of the amplifier: **Red**, **White** and **Green**.

White LED indication:

Power is off.

Green LED indication:

The Green light indicates amplifier is working normally.

The Green light goes out whenever the following occur:

- Loss of power to the amplifier
- Red light is on
- A ground or Remote Reset/Inhibit Input is applied at PIN 7 of J1

Red LED indication:

The Red light indicates the Bus voltage has exceeded 150 volts.

This condition can exist if:

- The shunt regulator fuses are blown.
- When a shunt regulator is required to handle regenerative motor energy, due to excessively high inertia loads.

Troubleshooting the LED's:

The LED also indicates ground fault conditions that can exist where the resistance to ground is relatively low so that the amplifier can not detect them. Damage is likely to happen in the power bridge if this occurs.

Ground Fault:

Though not an LED color, the LED will give an indication if one of the output wires to the motor is shorted to the ground.

This condition can exist due to:

- Faulty or pinched wiring
- Motor arcing to its case ground

Over Temp: This LED provides indication of over temperature of the heat sink where the sensor is set to trip at 75-80 °C.

This condition might exist due to:

- Insufficient cooling of the Amplifier
- Ambient cabinet temperature is too high

Excessive RMS: Excessive RMS means the amplifier was required deliver current for a period too long and beyond its continuous capability. This condition can exist if a machine is asked to perform a task greater that for which it was designed.

It will indicate if a motor:

- Is mechanically stalled or binding
- Has a partially shorted armature

Surge Current: This LED provides indication for an excessive amount of current through the power transistors in the output power bridge.

Appendix 3

Spindle Amplifier Information

Spindle Drive Parameters

Non Indexing spindles

NOTE : (EMS ONLY) At Parameter 00, Select Password 3.

Parameter 01, Digit 3 = 0 (Decelerate To Stop)

Parameter 02 = 120 Hz. (Maximum Output Frequency)

Parameter 09 = 1 Sec. (Acceleration Time)

Parameter 10 = 1 Sec. (Deceleration Time)

**ALL OTHER PARAMETERS REMAIN AT THE NORMAL
FACTORY SETTINGS.**

NOTE : A dynamic braking (db) resistor is required for these parameters.

Required db resistors :

5 HP 230 VAC, 3 PHASE : 25 Ohm, 450 Watt.

5 HP 460 VAC, 3 PHASE : 100 Ohm, 450 Watt.

3 HP 230 VAC, 3 PHASE : 50 Ohm, 225 Watt.

Indexing spindles and Vector drives

Please refer to the Baldor drive manual for all information regarding these parameters.

Appendix 4

Machine Parts List

Parts List

See exploded view for item location

Item #	Part Number	Qty Used	Description
1	763-0109	1	CNC Enclosure
2	425-1001	1	Hand wheel
3	763-0107	1	Hand wheel Enclosure
4	763-0102	1	Cable Guard Top Cover
5	763-0101	1	Cable Guard
6	763-0103	1	Top Enclosure Side Plate
7	763-0106	1	Spindle plate with door Assembly
8	763-0119	1	Encoder Rear Access Plate
9	514-1000	1	PSI Regulator
10	461-1004	1	Fan Assembly (Fagor)
11	421-2008	1	CNC Controller 8025T
12	763-0100	1	Top Enclosure Assembly
13	763-0105	1	Z Axis Motor Plate
14	481-1004	1	Light Fixture
15	363-1000	1	Glass
16	764-0103	1	X Axis Motor Cover
17	345-1012	1	Timing Belt Pulley
18	711-0105	1	Encoder Mounting Plate
19	345-1012	1	Timing Belt Pulley
20	764-0113	1	Encoder Box
21	711-0102	1	Encoder Bracket 2 Hole
22	763-0122	1	Spindle Drip Cover
23	427-1007	1	Motor Drive-Standard Z Axis
24	763-0104	1	X Axis Motor Sliding Plate
25	614-4212/3-3	1	Motor Mount Cap-Z Axis
26	392-1002	2	Couplings Flexible 375
27	614-4200/3-3	2	X & Z Axis Motor Mount
28	313-1002	2	Bearing & Support Unit
29	761-0101	1	Telescoping 3 Box Cover (rear)
30	761-0100	2	Telescoping 6 Box Cover (Left & Right)
31	312-1004	2	Linear Bearing 480 large with ANZ
32	311-2013	1	Ballscrew-Flange Type
33	611-2000/4-4	1	Spindle Head
34	614-4208/2-2	1	Spindle Cover
35	324-1000	1	Spindle GT-27 5C
36	342-1017	1	Timing Belt-Encoder
37	346-1003	1	V Belt-10 Groove (770)
38	427-1005	1	Motor Drive-Standard X Axis
39	421-1008	2	Cable-Motor (2 Right Angle) Gray 30

Parts List

See exploded view for item location

Item #	Part Number	Qty Used	Description
40	613-7000/3-3	1	Tool Plate
41	763-0121	1	Chip Guard
42	764-0106	1	X Axis Back Wiper Plate
43	611-8000/3-3	1	X Axis Cover
44	764-0104	1	X Axis Front Wiper Plate
45	764-0108	1	X Axis Way Cover
46	614-4201/3-3	1	Z Axis Yolk
47	614-4202/3-3	1	Motor Mount Cap X Axis
48	311-2009	1	Ballscrew 171 Large 5
49	762-0120	1	Electronics Cover Plate #2
50	448-1002	2	Home Switch
51	312-1006	2	Linear Bearing 508 large with FLZ
52	763-0120	1	Drip Cover
53	614-4203/3-3	1	X Axis Plate
54	427-2004	1	Motor Spindle-Super E
55	348-1001	1	Bushing
56	347-1004	1	Sheave 10 groove J 475 1610
57	367-2002	1	Spring Cylinder 7/8x1/4
58	612-4000/3-3	1	Spindle Motor Plate
59	611-1000/3-3	1	Bed
60	762-0118	1	Electronics Cover Plate
61	762-0111	1	Cable Plate
62	762-0107	2	Chip Conveyor Wall Plates
63	762-0100	1	Base
64	762-0104	1	Louvered Plate 15x28
65	524-1001	1	Lubrication Pump (30 Min) 110v with oil
66	762-0119	1	Barfeed Access Plate 5x5
67	428-1000-Blue	1	Safety Switch 220-Blue
68	461-1000	2	Fan
69	521-1000	1	5 Micron Filter
70	762-0102	2	Filter Guard Support
71	461-1003	2	PDU Filter
72	445-1003	1	Contactator
73	428-1001	1	Power Supply Kit w/ Transformer
74	423-1000	2	Drive Amps-(260) Standard
75	762-0106	1	PDU Top Drawer
76	762-0105	1	PDU Bottom Drawer
77	762-0103	1	Louvered Plate 15x16
78	768-1001	1	Drip Tray

Parts List

See exploded view for item location

Item #	Part Number	Qty Used	Description
79	764-0114	1	Coolant Gun Bracket
80	512-1001	1	Gauge Panel Mount
81	762-0101	4	Drip Tray Anchor Brackets
82	543-1003	1	Wash Gun
83	532-1004	1	Pump Suction-3 phase
84	453-1000	1	Relay-M Function-10 Amp
85	452-1000	1	Solenoid
86	762-0115	2	PDU/Coolant Plate
87	762-0116	1	Strainer Box/Drawer Assembly
88	456-1000	2	PDU Resistor
89	426-1007	1	Inverter Drive 5hp/230v/pc3

Exploded View

This page is replaced with an AUTOCAD FILE

Appendix 5

Troubleshooting Guide
